



Part # 11160298 - 1967-1969 GM "F" Body HQ Series ShockWave System

Recommended Tools

Front Components:

11163001	Front ShockWaves
11162899	Front Lower StrongArms
11163699	Front Upper StrongArms
11009300	Ridetech Tall Spindle
11169120	Front SwayBar

Rear Components:

11167199	Rear 4Link System
21150701	Rear ShockWaves

Miscellaneous Components:

85000000	Spanner Wrench
----------	----------------

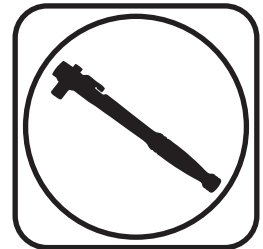

1967-1969 GM "F" Body ShockWave Installation Instructions

Table of contents

Pages 2-5.....	Front ShockWaves
Pages 6-9.....	Front Lower StrongArms
Pages 10-15.....	Front Upper StrongArms
Pages 16-19.....	Tall Spindle
Pages 20-23.....	Front SwayBar
Pages 24-40.....	Rear 4-Link
Pages 41-42.....	Rear ShockWaves
Pages 43.....	Notes and Care of Your ShockWaves
Pages 44.....	Shock Adjustment





Part # 11163001 - 67-69 GM F-Body Front HQ Series Shockwave

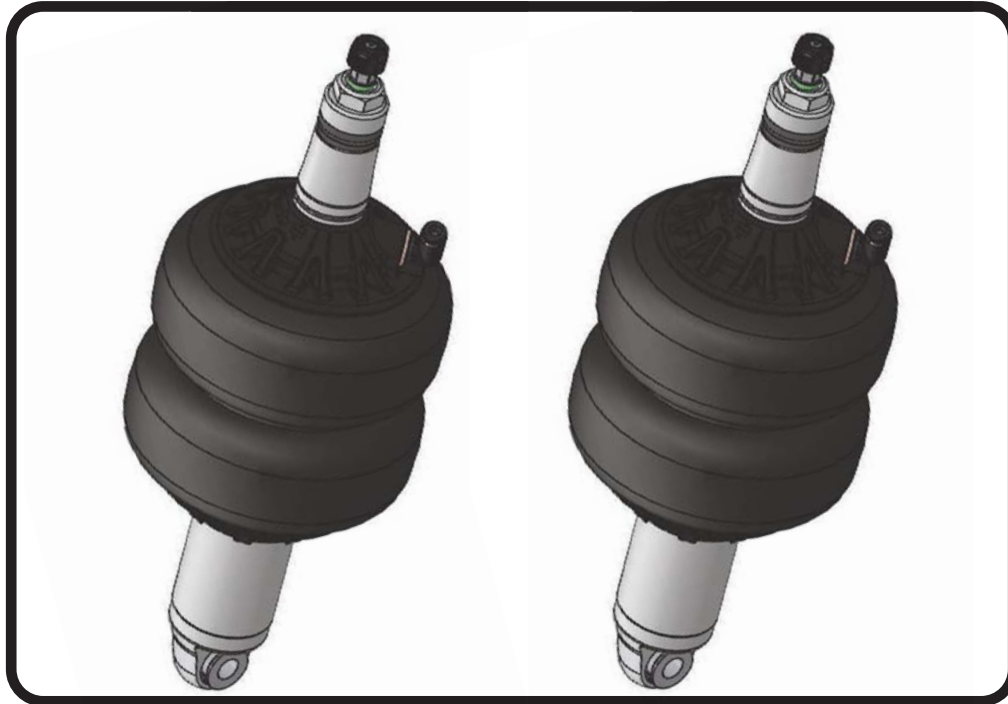

Recommended Tools

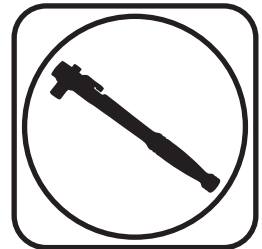

1000 Series Bellow, 2.75" Stud/Eye 3.6" Shock Installation Instructions

Table of contents

Page 3..... Included components

Page 4-5..... Shockwave Installation

ShockWave Dimensions:

Center of bearing to Center of bearing:

Compressed: 11.05"

Ride Height: 12.88"

Extended: 14.07"

THE DELRIN BALL REQUIRES A 3/4" HOLE FOR THE FLANGE TO GO THROUGH. THIS CAN BE DRILLED WITH A UNIBIT.



Major ComponentsIn the box

Item #	Part #	Description	QTY
1	982-10-803	3.6" Stroke HQ Series Shock	2
2	90009989	2.75" Stud Top (Installed on Shock) - Includes Adjuster Knob & Screw	2
3	24090199	1000 Series 6.5" Double Convoluted AirSpring	2
4	234-00-153	AirSpring Locking Ring (Installed on shock)	2
5	99055000	Locking Ring Set Screw (Installed on shock)	2
6	90002062	Spacers - INCLUDED WITH STRONGARMS	4
7	90002313	2.75" Aluminum Stud Top Base	2
8	90001904	Bottom Delrin Ball	2
9	90001903	Top Delrin Ball	2
10	90001902	Delrin Ball Aluminum Top Cap	2
11	99562003	9/16" -18 Thin Nylok Nut	2
12	210-35-120-0	Adjuster Knob - (90009989 assembly)	2
13	90009969	#4-40 X 1/4" SS, 18-8 Pan Head Torx Cap - (90009989 assembly)	2
	70012161	2.75" Stud Top Metering Rod (installed in stud top)	2
	90001994	5/8" ID Bearing (installed in shock and eyelet)	4
	90001995	Bearing Snap Ring (installed in shock and eyelet)	8

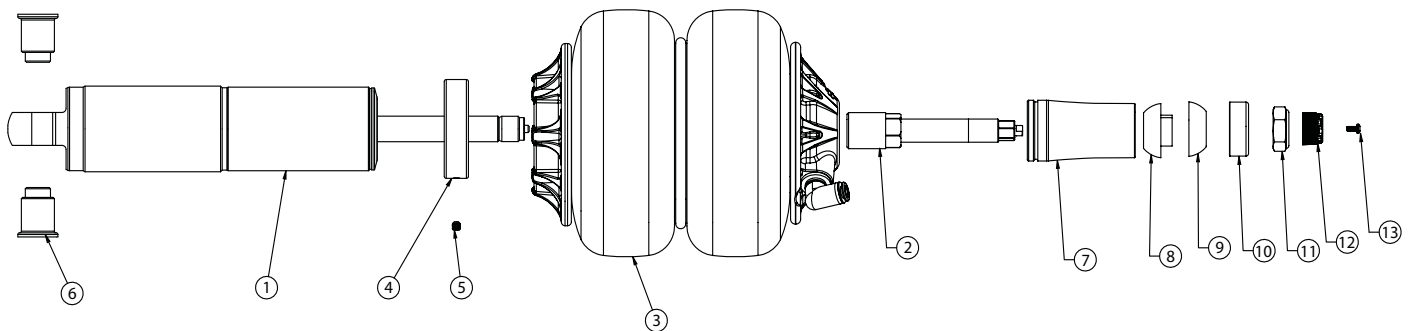

THE DELRIN BALL REQUIRES A 3/4" HOLE FOR THE FLANGE TO GO THROUGH. THIS CAN BE DRILLED WITH A UNIBIT.

WARNING: ATTEMPTING TO REMOVE THE AIR FITTING WILL DAMAGE IT AND VOID THE WARRANTY.



ShockWave Installation

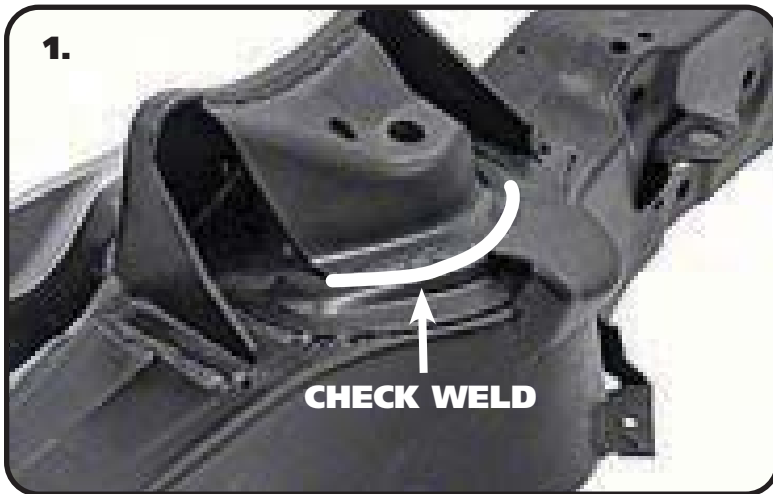

1. Check the weld in the area pointed out. We have seen some very poor factory welds in this area. If it doesn't look adequate to support the vehicle, reweld the area.



2. Drill the OEM shock hole out to 3/4". This can be done with a Unibit. The Shockwave stud top will come in contact with the coil spring retainer, so it must be opened up towards the engine. A die grinder works well here.



3. Some trimming must also be done on the outside of the frame pocket to allow clearance for the Shockwave.



ShockWave Installation

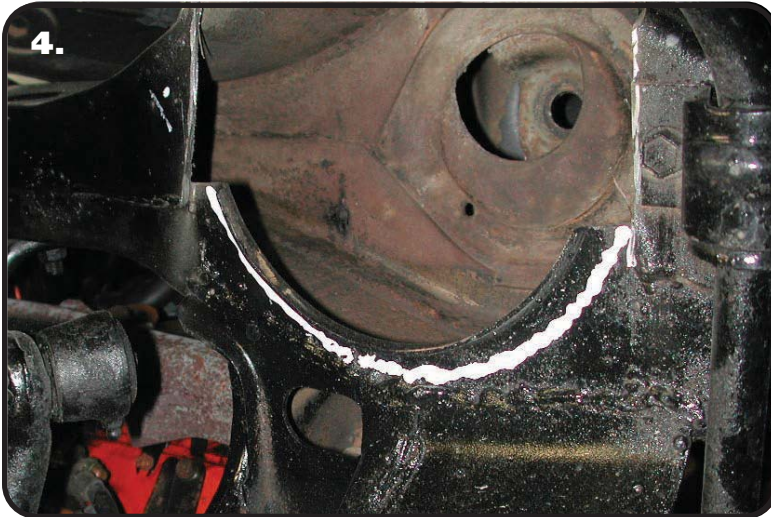

4. To allow clearance for the Shockwave, some trimming must be done on the inside of the coil spring pocket as shown by the white line in the picture. This is best done with either a cut off wheel or plasma cutter. Grind all cuts smooth when finished.

Note: It may be helpful to go ahead and install the lower StrongArms and Shockwaves to determine exactly what needs to be removed.

Note: The airline must also be routed at this time. It can be ran through the subframe toward the rear of the vehicle.

5. The air fitting location can be rotated by twisting the bellows assembly separate of the shock. Place the Shockwave into the coil spring pocket with the stud sticking through the OEM shock hole. See assembly **Diagram 4**. OEM Shock hole **must** be drilled out to $\frac{3}{4}$ "

1. Stud top aluminum base
2. Delrin ball lower half
3. Delrin ball upper half
4. Aluminum cap
5. 9/16" SAE Nylok jam nut
6. Threaded stud (screwed onto shock shaft)
7. Rebound adjusting knob
8. Screw

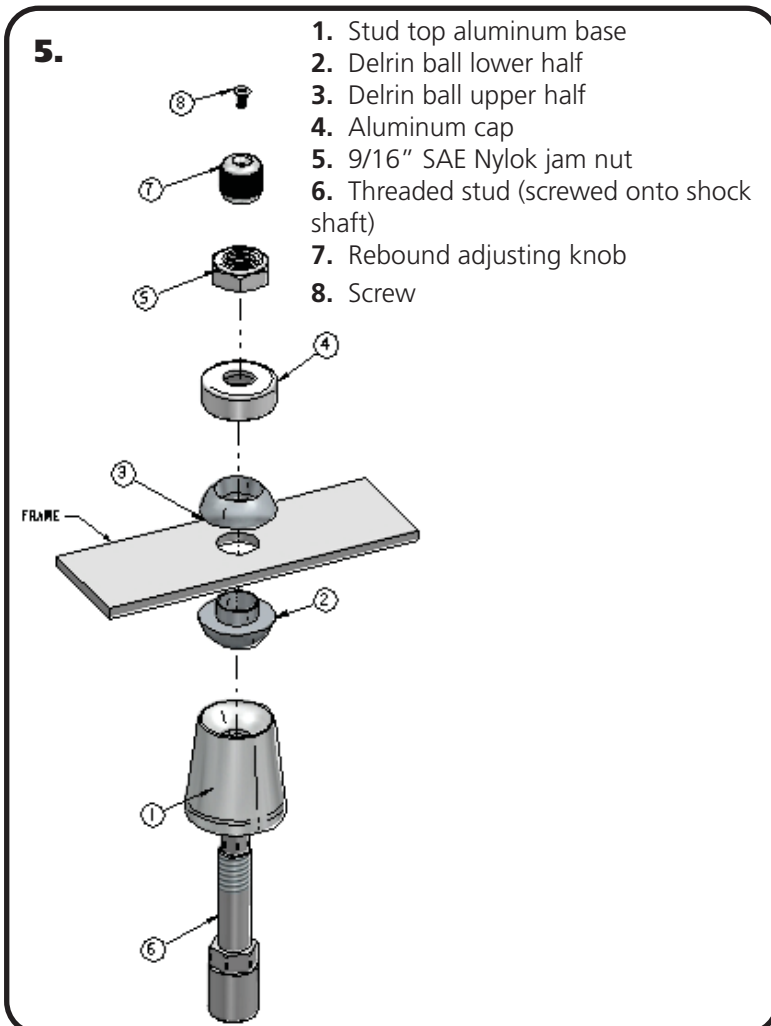



Part # 11162899

1967-1969 GM F-Body, 1968-74 GM X-Body Front Lower StrongArms



Recommended Tools

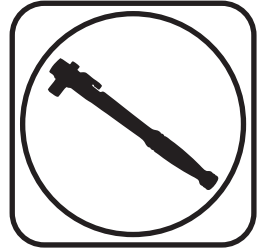

1967-1969 GM F-Body Lower StrongArms Installation Instructions

Table of contents	
Page 7.....	Lower Control Arm Components
Page 8.....	Getting Started & Installation
Page 9.....	Installing Spindles and Steering Stop



Lower Control Arm ComponentsIn the box

Item #	Part Number	Description	QTY
1	90000621	Driver Lower Control Arm (Shown)	1
1	90000622	Passenger Lower Control Arm	1
2	90000898	Lower Ball Joint Assembly	2
3	70010759	Delrin Bushing - with 2" Diameter Ledge	8
4	90002062	CoilOver Bearing Spacers	4
5	90000516	1/2" ID Inner Sleeve	4
6	99501005	1/2"-13 x 3 1/2" Hex Bolt	6
7	99502009	1/2"-13 Nylok Nut	6
8	99503014	1/2" SAE Flat Washer	12
9	99371005	3/8"-16 x 1 1/4" Hex Bolt	2
10	99372012	3/8"-16 Hex Nut	2

Driver Side Shown

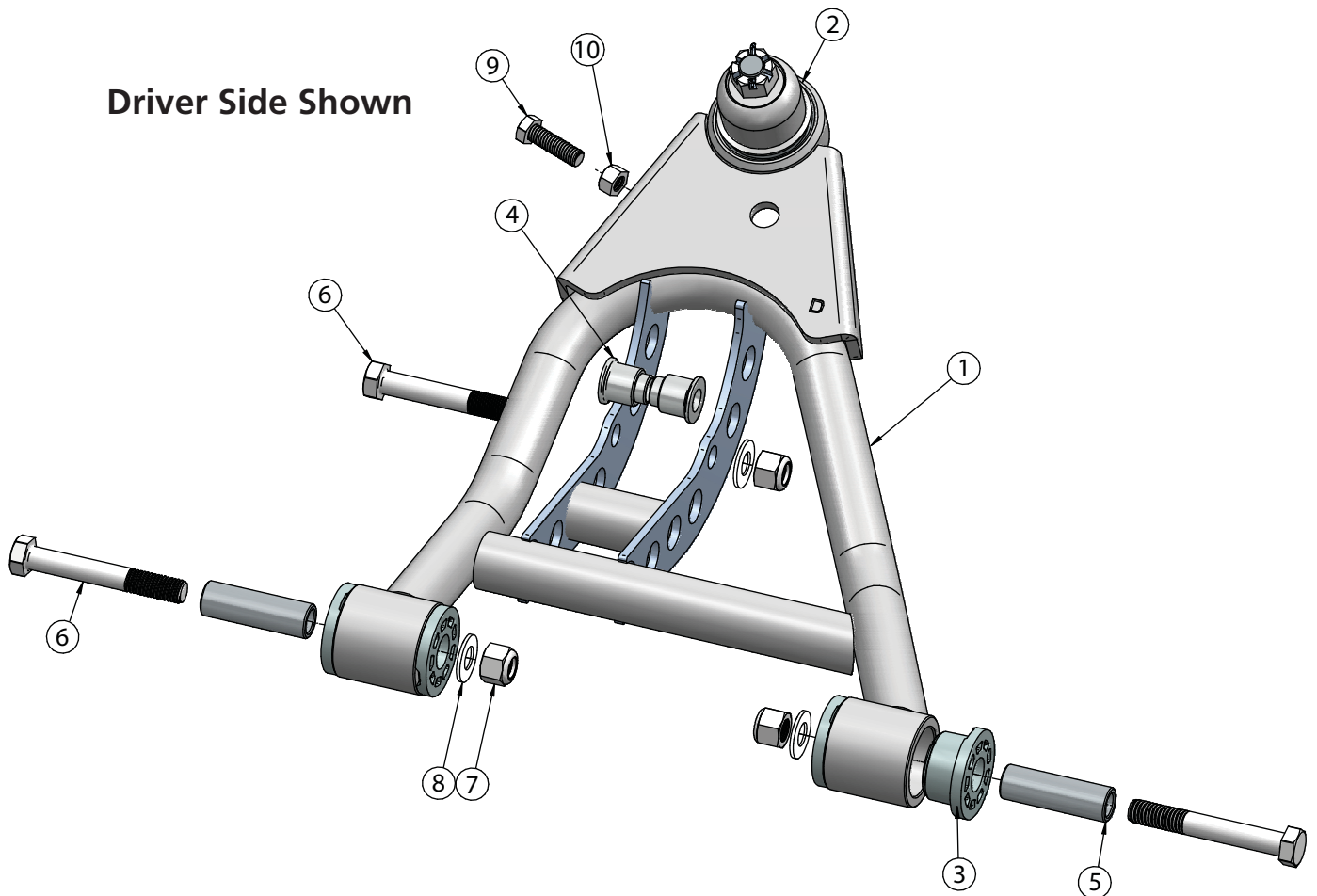



Getting Started.....

Congratulations on your purchase of the Ridetech F-Body StrongArms. These StrongArms have been designed to give your F-Body excellent handling along with a lifetime of enjoyment. Some of the key features of the StrongArms: Ball joint angles have been optimized for the lowered ride height, Delrin bushings are used to eliminate bushing deflection along with providing free suspension movement through the entire travel. The Geometry has been optimized for excellent handling, and drive ability. The Delrin bushings are made from a material that is self lubricating so no grease zerks are needed.

Note: These control arms are designed for use with the Ridetech CoilOvers and the MuscleBar swaybar. **The factory shocks and springs or the factory sway bar will not fit these arms.**

Installation

1. Remove the entire lower control arms from the car. If you are replacing the upper control arms and spindle, remove them too. Refer to a Factory Service Manual for the proper method.
2. Drill the factory upper shock mounting hole to 3/4". This can be done easily with a Unibit.

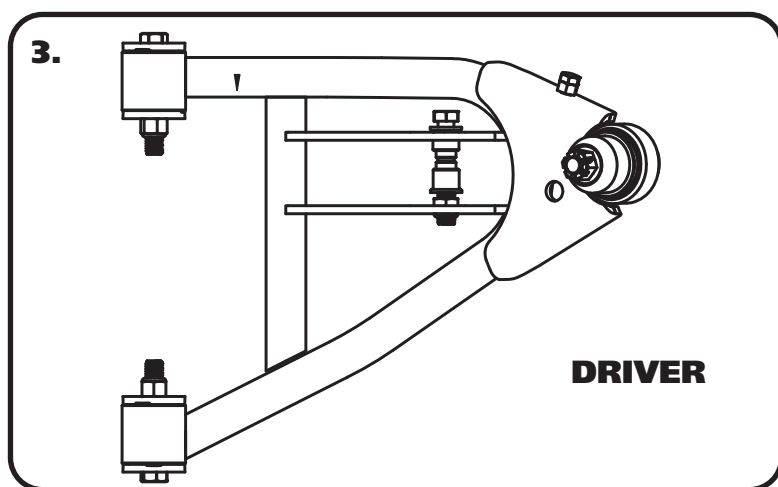

3. After removing the factory lower control arm, clean the bushing mounting surfaces on the frame. The Control Arms are marked "D" for Driver and "P" for Passenger. The Ballpoint Pin points up and the Sway bar mount is on the front side of the arm. Fasten the lower arm to the frame with the hardware supplied.

Note: On some cars the frame brackets may be pinched and will need to be spread back apart to allow the bushing to slide in.

Install the CoilOvers at this time. Refer to the CoilOver instructions for Assembly.

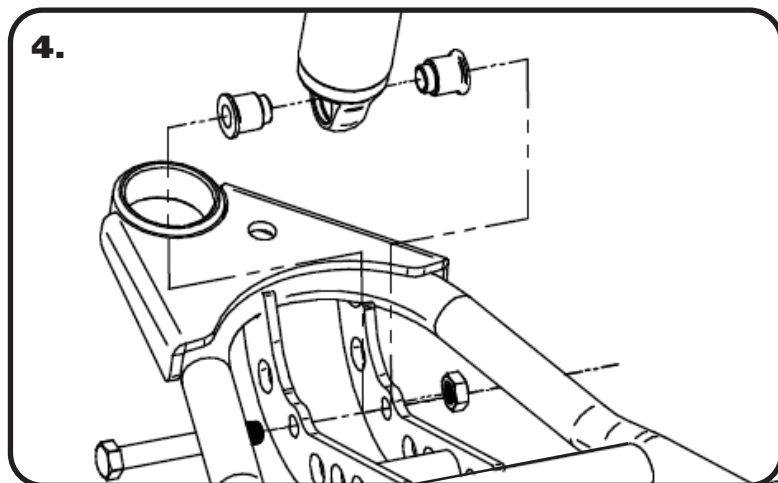

4. Insert the Bearing Spacers into the lower shock bearing. The SMALL end goes into the bearing. Swing the Control Arm up, line up the 1/2" holes with the bearing spacers, insert 1/2"-13 x 3 1/2" bolt. Install a 1/2" flat washer and nylok nut. **Note: The shock bolt will need to be installed from the rear with the threads pointing to the front of the car.**



Installing Spindle & Setting Steering Stop

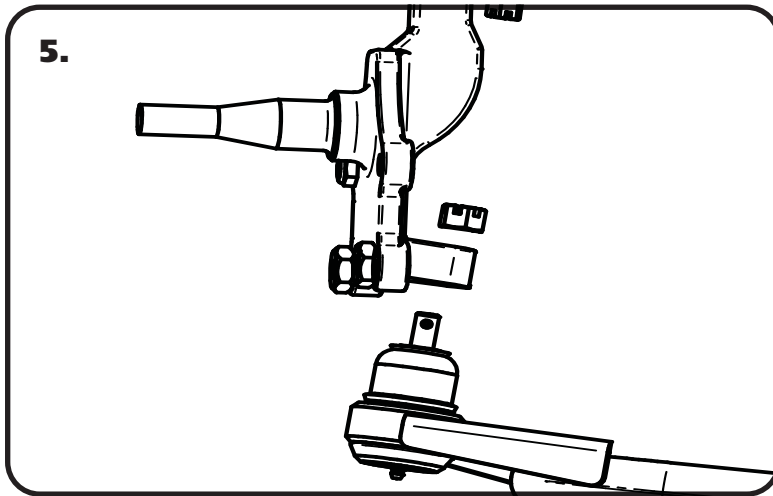

5. Attach the Spindle to the control arms.

Torque Specs:

Lower Ball joint - 65 ftlbs and tighten to line up cotter pin.

Install the Cotter Pin after tightening the ball joint nut.



5. Thread the 3/8"-16 nut onto the 3/8"-16 x 1 1/4" bolt. Thread it into the front hole of the ball joint plate. You will need to adjust the steering stop to suite your needs. This setting will vary depending on wheel and tire size and other suspension components.

NOTE: If you are running the TruTurn setup, this steering stop bolt will not be used.

6. Tighten all fasteners. If you are going to install the Ridetech MuscleBar, now is a good time to do it.

Suggested Alignment Specs:

Camber: Street: -.5 degrees
Caster: Street: +3.0 to + 5.0 degrees
Toe: Street: 1/16" to 1/8" toe in



Part # 11163699

1967-1969 GM F-Body, 1968-74 GM X-Body Front Upper StrongArms



Recommended Tools

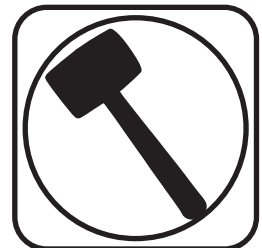
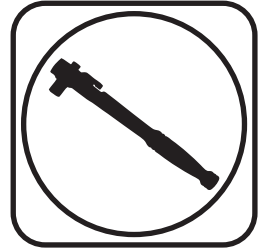

1967-1969 GM F-Body Upper StrongArms Installation Instructions

Table of contents

- Page 11..... Upper Control Arm Components
- Page 12..... Getting Started
- Page 13..... Caster Explained
- Page 14..... Offset Upper Control Arm Cross Shaft
- Page 15..... Installing Spindle and Alignment



Upper Control Arm ComponentsIn the box

Item #	Part Number	Description	QTY
1	90002390	Driver Upper Control Arm (Shown)	1
1	90002391	Passenger Upper Control Arm	1
2	90000908 kit	Upper Ball Joint Kit	2
3	90000914 kit	Caster Slug Cross Shaft Kit	2
4	70010883	Caster Slug	4
5	70010759	Outer Delrin Bushing with 2" Lip	4
6	70010827	Inner Delrin Bushing with 1.75" Lip	2
7	70010826	Inner Delrin Bushing with No Lip	2
8	90002737	Aluminum T-Washer	4
9	70001323	Bumpstop	2
10	99373003	3/8" SAE Flat Washer - Bumpstop	2
11	99372002	3/8"-16 Nylok Nut - Bumpstop	2
12	99622005	5/8"-18 Jam Lock Nut - Included with 90000914 kit	4
	99433004	7/16" USS Flat Washer - Control Arm Mounting - NOT SHOWN	4

Driver Side Shown

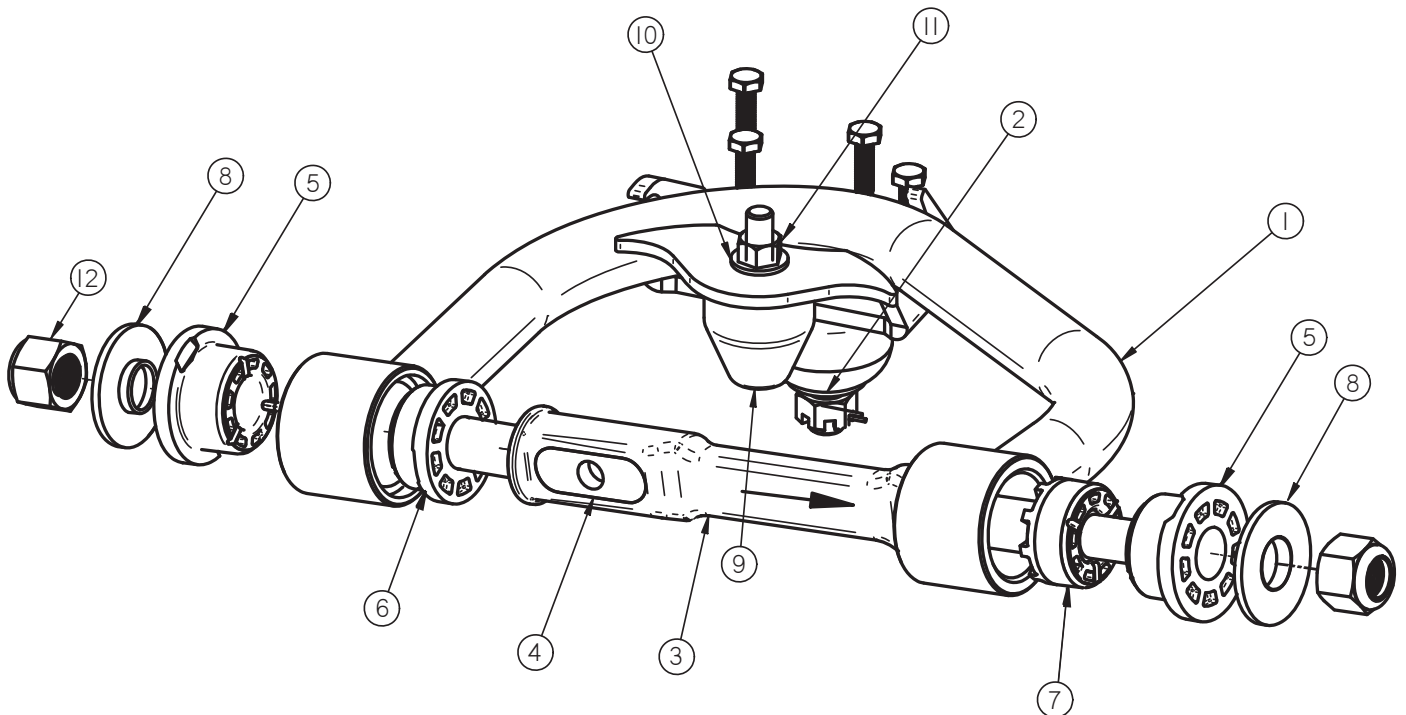



Getting Started.....

Congratulations on your purchase of the Ridetech F-Body StrongArms. These StrongArms have been designed to give your F-Body excellent handling along with a lifetime of enjoyment. Some of the key features of the StrongArms: Ball Joint angles have been optimized for the lowered ride height, Delrin bushings are used to eliminate bushing deflection along with providing free suspension movement through the entire travel. The Geometry has been optimized for excellent handling and driveability. The Delrin bushings are made from a material that is self lubricating so no grease zerks are needed.

When assembling the Control Arms tighten the cross shaft nuts enough to create drag on the delrin bushings, the arm should still move through its travel by hand.

Installation

1. Remove the entire upper control arms from the car. If you are replacing the lower control arms and spindle, remove them too. Refer to a Factory Service Manual for the proper method.

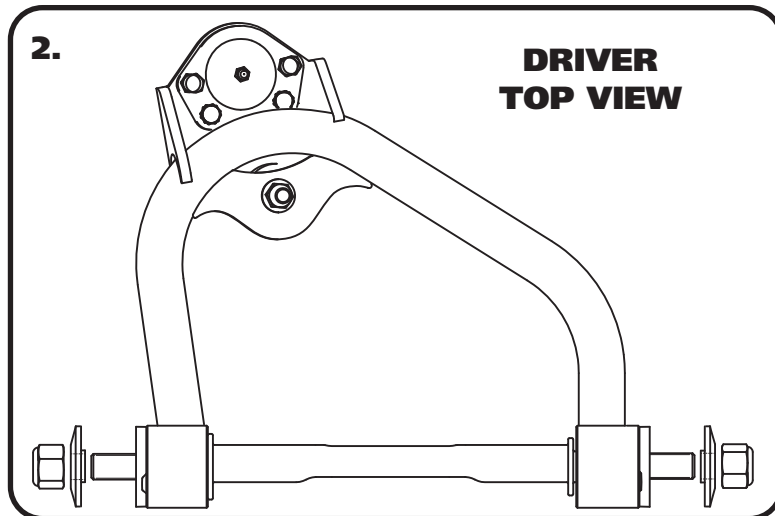

2. The Upper Control Arm is attaching the factory mount using factory hardware. The driver side arm is shown in **Figure "2"**. The Ball Joint located on the arm to the rear of the car. Install the T-Washers and 5/8"-18 Lock Nuts using **Figure "2"** as a reference. These can be tightened after installing the control arms on the car.

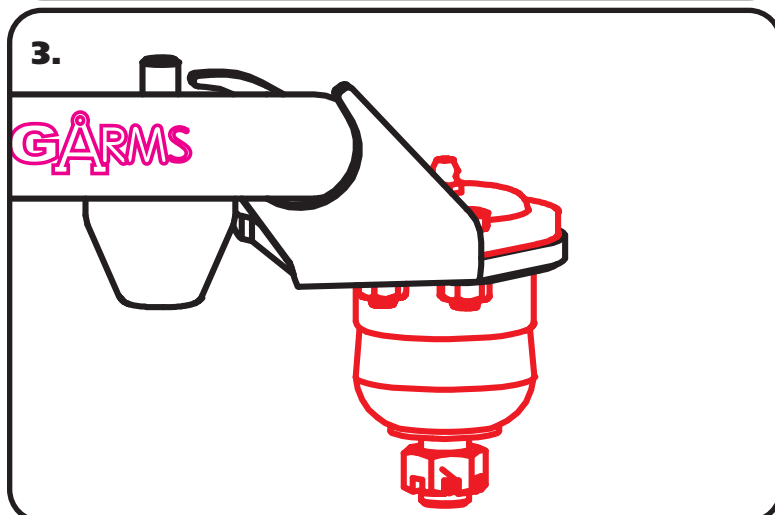

3. Install the Ball Joints in the control arms using **Figure "3"** as a reference. Torque the hardware to 10 ftlbs



Caster Explained

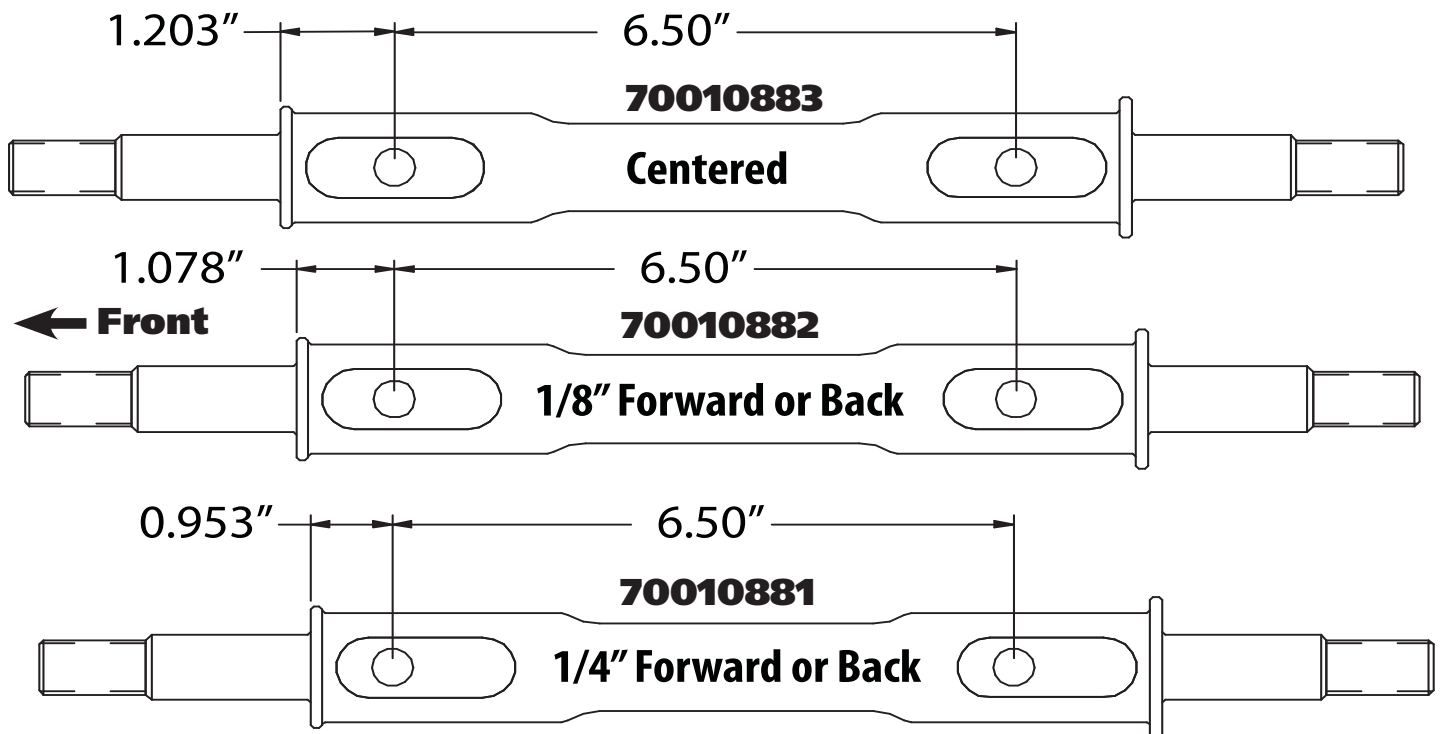

These StrongArms come equipped with a changeable caster slug setup. This allows you to add or remove caster from the front suspension, if desired. The caster slugs that come supplied in the kit are setup to be centered. The caster slugs allow you to add or remove caster without having to use a stack of shims. If more or less caster is desired, optional slugs can be purchased from Ridetech or your Ridetech dealer.

1/8" = 70010882

1/4" = 70010881

Caster Explained:

To understand caster you need to picture an imaginary line that runs through the upper balljoint and extends through the lower balljoint. From the side view the imaginary line will tilt forward or backward. The tilting of this imaginary line is defined as caster.

Caster is measured in degrees by using a caster gauge. If the imaginary line described above tilts towards the back of the vehicle at the top, then you have positive caster. If the imaginary line tilts forward then you have negative caster.

Positive caster provides the directional stability in your vehicle. Too much positive caster will make the steering effort difficult. Power steering will allow you to run more positive caster. Negative caster requires less steering effort but will cause the vehicle to wander down the highway.



Offset Upper Control Arm Shaft

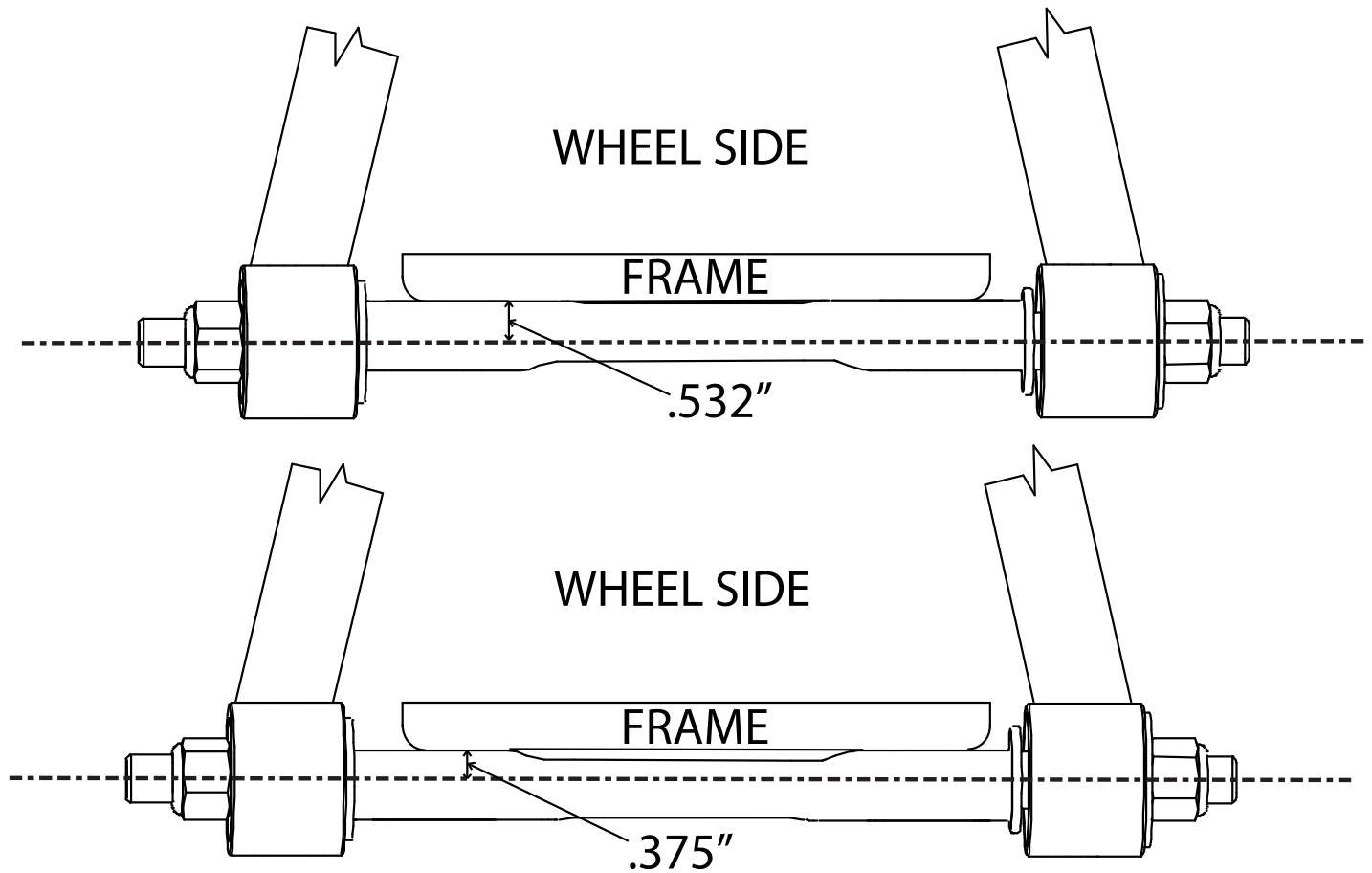

The cross shaft that is used in the upper control arms is offset. The offset combined with the caster slug option allows you to achieve the alignment setting you desire with minimal shims. To change the direction the Icon faces simply spin the cross shaft in the control arm.

If you are after a **Street Alignment** bolt the upper control arm to the frame mount with the arm offset to the outside of the car. The Ridetech Icon and Caster Slugs will be facing the wheel.

If a more aggressive **Track or Autocross** alignment is desired, bolt the control arm to the frame bracket with the arm offset to the inside of the car. The Ridetech Icon and Caster Slugs will be facing the engine.



Installing Spindle and Alignment



4. The Upper Control Arm is attaching the factory mount using factory hardware with the supplied 7/16" Flat Washer under the OEM Nut. The driver side arm is shown in **Figure "2"**. The Arrow on the Cross shaft points to the front of the car. **Page 4 & 5** has information about Caster and the Caster Slugs.

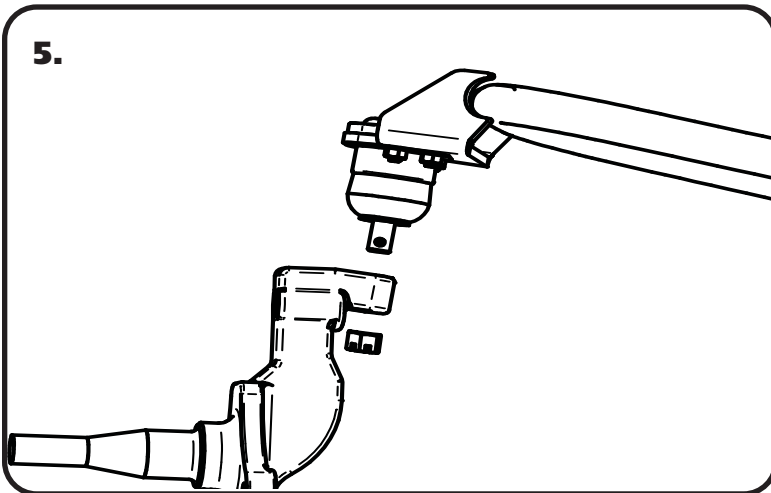

5. Attach the Spindle to the control arms.

Torque Specs:

Upper Ball Joint - 50 ftlbs and tighten to line up cotter pin.

Install the Cotter Pin after tightening the ball joint nut.

6. Tighten all fasteners.

When assembling the Control Arms tighten the cross shaft nuts enough to create drag on the delrin bushings, the arm should still move through its travel by hand.

Suggested Alignment Specs:

Camber: Street: -.5 degrees
Caster: Street: +3.0 to + 5.0 degrees
Toe: Street: 1/16" to 1/8" toe in



Part # 11009310 - A/F/X Tall Spindle Kit



Recommended Tools



A/F/X Tall Spindle Kit

Installation Instructions

Table of contents

- Page 17..... Included Components and Hardware
- Page 18..... Getting Started and Installation
- Page 19..... The Finish

THIS SPINDLE IS DESIGNED TO FIT 64-72 GM A-BODY, 67-69 GM F-BODY, AND 68-74 GM X-BODY.

THESE SPINDLES ARE A DIRECT REPLACEMENT FOR OEM DISC BRAKE SPINDLES. IF YOUR CAR HAS DRUM BRAKES, YOU WILL HAVE TO CONVERT IT TO DISC BRAKES. THEY WILL ACCEPT ANY BRAKE KIT THAT IS DESIGNED FOR THE OEM DISC BRAKES SPINDLES.



Major ComponentsIn the box

Item #	Part #	Description	QTY	
1	11009307	Spindles (Pair)	1 pair	
2	90002743	3/4"-20 Spindle Nut Kit	1 kit	
Item #	Part #	Description	Usage	QTY
Hardware				
3	99501009	1/2"-20 x 1 3/4" Hex Bolt	Steering Arm to Spindle	2
4	99502005	1/2"-20 x 2" Hex Bolt	Steering Arm to Spindle	2
5	99503015	1/2" Split Lock Washer	Steering Arm to Spindle	4
6	99503014	1/2" SAE Flat Washer	Steering Arm to Spindle	4

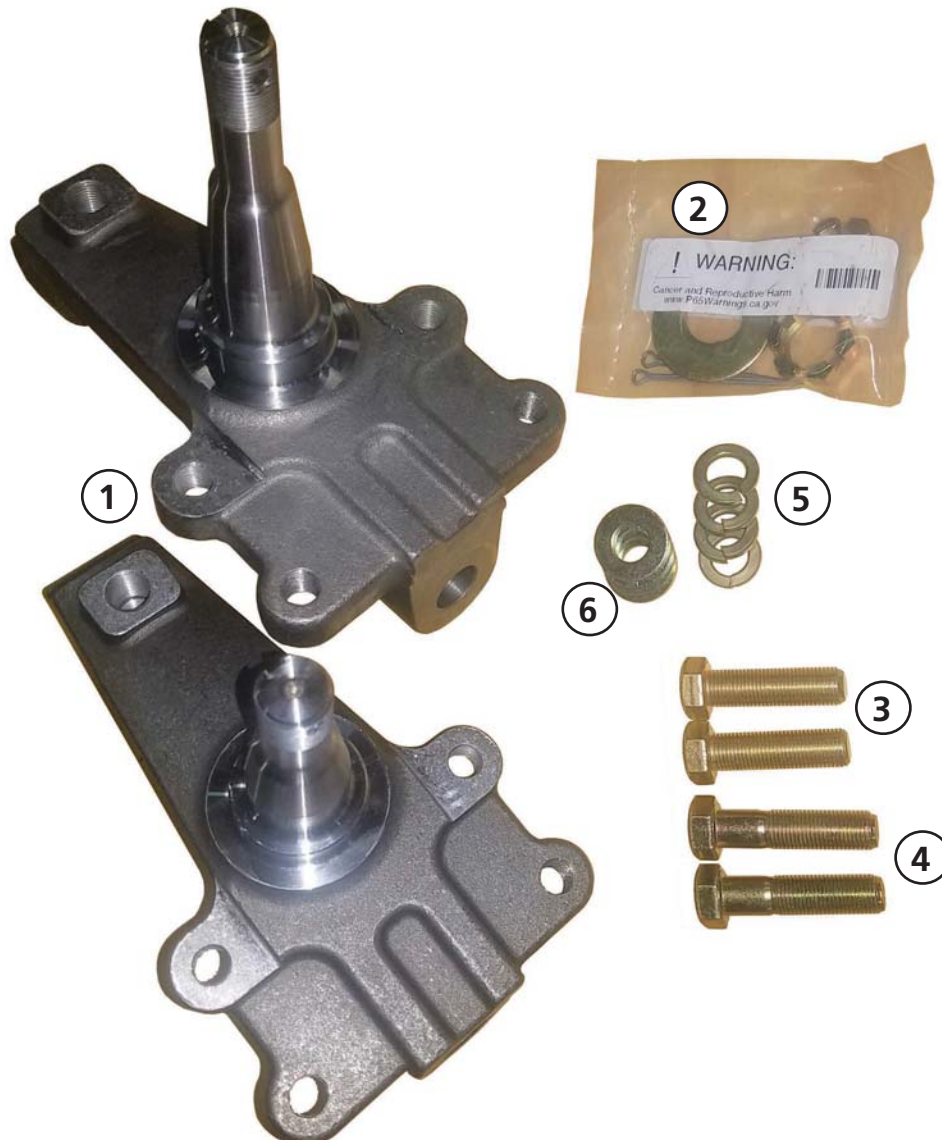



Getting Started.....

These spindles will fit '67-69 Camaro, '64-'72 Chevelle, and '68-'74 Nova. They will provide a 2" drop, and are taller than stock to improve the car's cornering ability. The raised upper ball joint induces negative camber gain and positive caster gain. This helps keep the tires flat on the pavement when cornering. This camber action change also raises the roll center for less body roll, and transfer the car's center of gravity inboard in the turn as well. You will see an appreciable improvement in handling.

These spindles are designed around stock disc brake spindles and will accept any disc brake set up designed for those. **The only modification we discovered to be necessary was a small trim on the bottom of the stamped 1/4" steel caliper bracket that holds the caliper.** It is an area that is not stressed and will not cause any loss of strength. Trim only enough to make the caliper bracket clear the spindle. If you are using the factory dust shields, they will also require trimming. If your car came with drum brakes, be sure to swap to the appropriate disc brake master cylinder and valving.

Installation



IF YOU HAVEN'T ALREADY DONE SO, REMOVE THE OEM SPINDLE. IF REUSING THE EXISTING CALIPERS, BE SURE TO SUPPORT THEM TO KEEP FROM PUTTING UNWANTED STRESS ON THE BRAKE LINES.

1 & 2. Remove the OEM steering arms from the spindles that were removed from the car. The steering arm will bolt to the **BOTTOM** set of holes in the spindle using the supplied 1/2" hardware. The mounting bosses of the steering arm are 2 different thicknesses. The thicker boss uses a 1/2"-20 x 2" hex bolt. The thin boss will use a 1/2"-20 x 1 3/4" bolt. Install a 1/2" split lock washer followed by a 1/2" SAE flat washer on each bolt. **We suggest using RED Threadlocker on the steering arm mounting hardware.** Line up the steering arm mounting holes with the bottom 2 holes of the spindle. Insert the 2" long bolt through the thick boss and the 1 3/4" long bolt through the thin boss, threading the bolts into the spindle. Torque the steering arm hardware to 100 ftlbs.



NOTE: Some steering arms have 7/16" mounting holes, they will need to be drilled out using a 1/2" drill bit.



The Finish

3. Attach the spindles to the control arms. Torque the ball joints and tie rods end using the torque specs below.

Torque Specs:

Lower Ball Joint -	65 ftlbs and tighten to line up cotter pin.
Upper Ball Joint -	50 ftlbs and tighten to line up cotter pin.
Tie Rod End -	35 ftlbs and tighten to line up cotter pin.

Wheel Bearing Tightening:

While turning the rotor, tighten the nut to 12 ftlbs with a torque wrench. Back off the nut one flat and insert the cotter pin. If the slot and pin hole don't line up, back off the nut an additional half flat or less as required to insert the pin. Note: Bearings should have zero preload and .001" to .008" of end movement. Bend the ends of the cotter pin, replace the dust cap. On a disc brake with the caliper removed, it's normal to have a slight amount of play detectable in the bearing.

5. Recheck all hardware before driving.

6. PUMP THE BRAKE PEDAL BEFORE DRIVING TO RESET THE BRAKE PADS TO THE ROTOR. IF YOU HAD THE CALIPERS REMOVED, BLEED THE BRAKE SYSTEM.

Suggested Alignment Specs:

Camber:	Street: -.5 degrees
Caster:	Street: +3.0 to + 5.0 degrees
Toe:	Street: 1/16" to 1/8" toe in



Part # 11169120 - 1967-1969 F-Body Front SwayBar

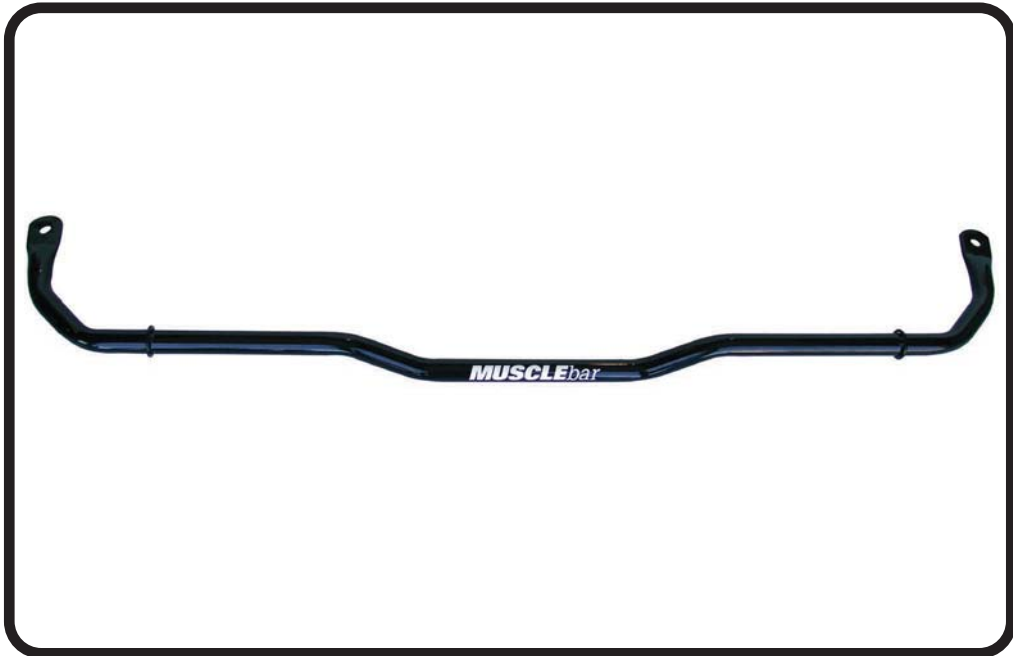

Recommended Tools



1967-1969 F-Body Front SwayBar Installation Instructions

Table of contents

Page 21..... Included components and Hardware List

Page 22..... SwayBar Installation

Page 23..... SwayBar Installation

INSTALL SWAYBAR BEFORE REINSTALLING THE FRONT SUSPENSION COMPONENTS.



Major ComponentsIn the box

Part #	Description		QTY
90002488	Front SwayBar		1
90002511	End Link Kit		1
70012402	Delrin Sway Bar Bushing Liner		2
90002539	Sway Bar Bushing		2
90002572	Sway Bar Bushing Strap		2
Part #	Description	Usage	QTY
99311001	5/16"-18 x 1" Hex Bolt	Bushing Strap to Frame	4
99313003	5/16" SAE Flatwasher	Bushing Strap to Frame	4
99313002	5/16" Split Lockwasher	Bushing Strap to Frame	4

Getting Started.....

IT IS VERY IMPORTANT TO ATTACH THE SWAYBAR TO THE FRAME BEFORE REINSTALLING THE FRONT SUSPENSION.

Remove the OEM Swaybar to prepare for the StreetGrip SwayBar installation.

This SwayBar kit utilizes a Delrin Liner in the SwayBar Bushing. The Delrin Liner allows the Swaybar to move freely and quietly in the Bushing. The Delrin is self-lubricating, no lubrication is required.



1. Insert the SwayBar through the frame into the OEM location. The SwayBar will be installed with the center of the SwayBar hanging down for engine clearance. The Delrin Liner is split on one side to ease installation. We found it easier to install by opening up the Liner enough to slide it onto the end of the SwayBar, then sliding it into position. It will open up and slide over the curves in the Bar. Install a Liner on each side of the SwayBar in the approximate location they will need to be when installing the SwayBar on the Car.



SwayBar Installation



2. Open up the Poly SwayBar Bushings and install them over the Delrin Sleeves.



3. Install Bushing Straps Over the Poly Sway-Bar Bushings.

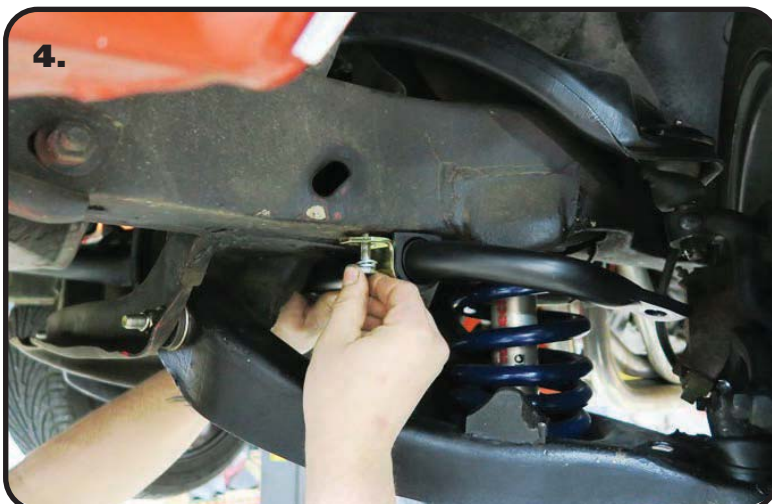

4. Slide the SwayBar into position on the Car. You may need to move the bushing assemblies on the swaybar to get the slots in the straps to align with the OEM threaded holes. Install a 5/16" Lockwasher and 5/16" Flatwasher on each 5/16" Bolt and thread them into the OEM Threaded holes. Do **NOT** Complete tighten the Hardware. It will be left partially loose until the End Links are installed.

Note: Straps may need ground for clearance, depending on the shape of the frame/spring pocket.



SwayBar Installation



5. Install the End Links. Use the photo in Diagram "5" and Diagram "6" for proper installation. The Threads on the bolt should point up. Tighten the Hex Nut enough to slightly compress the Bushings.

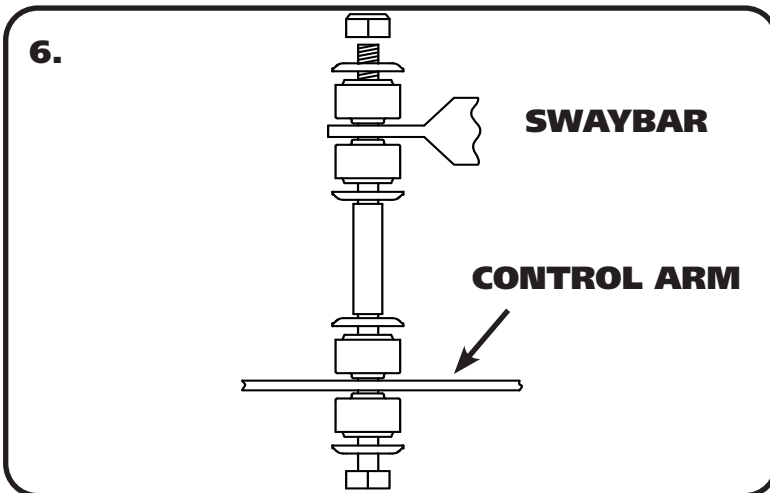

6. Install the End Links. Use Diagram "6" for proper installation. Tighten the Hex Nut enough to slightly compress the Bushings.

7. Tighten the Sway Bar Mounting Hardware. Center the mounting bolts in the slots before tightening the bolts.



Part # 11167199 -1967-1969 GM "F" Body Rear R-Joint Bolt-in 4 Link

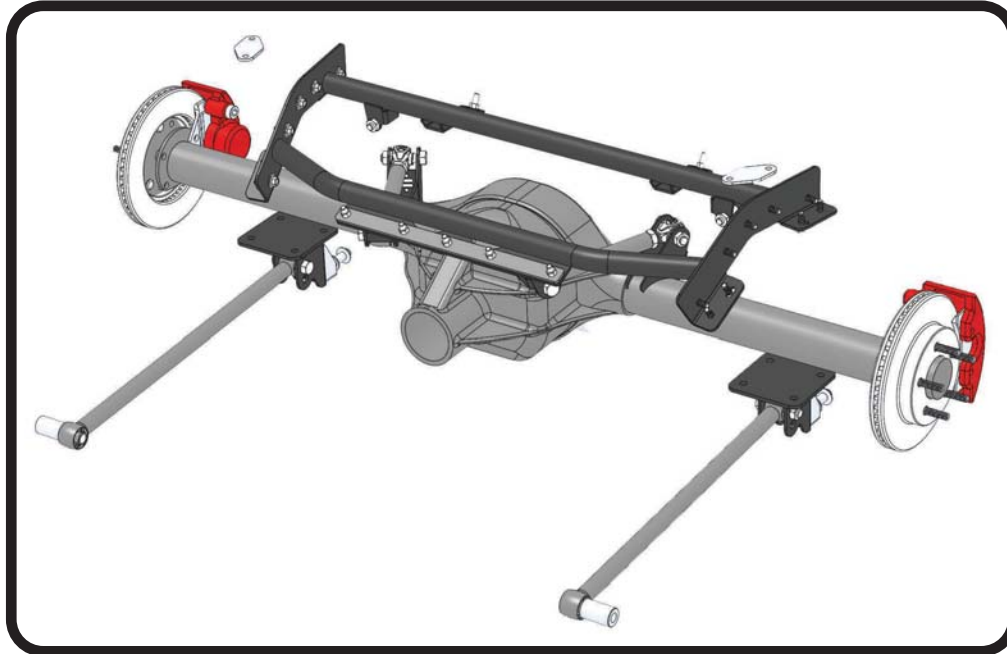

Recommended Tools

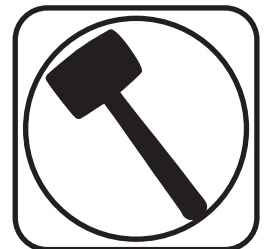

1967-1969 GM "F" Body Rear Bolt-in 4Link Installation Instructions

Table of contents

Page 25-26.....	Included Components
Page 27.....	Hardware List & Getting Started
Page 28.....	OEM Variation
Page 28-33....	Cradle Installation
Page 33.....	Lower Bar Installation
Page 34.....	Lower Bar & Shock Mount Installation
Page 35.....	Attaching Lower Shock Mount & Lower Bar
Page 36.....	Installing Lower Bar
Page 37.....	Setting Pinion Angle
Page 38.....	Upper Bar Axle Tab Installation
Page 39.....	Installing Axle Tabs
Page 40.....	Installing ShockWaves/CoilOvers & Shock Block Off





Major ComponentsIn the box

Item #	Part #	Description	QTY
1	90002722	Upper Cradle	1
2	90002723	Forward Tab Inner Brace	1
3	90001844	Trunk Reinforcement	2
4	90000523	Shock Block Off Plate	2
5	90002077	Lower Axle Mount - Driver	1
6	90002078	Lower Axle Mount - Passenger	1
7	90002819	Lower Bar Assembly - Driver - 25 1/16" center to center	2
8	70013537	Front R-Joint Spacer	2
9	90001318	RH R-Joint Threaded Housing End (installed in bars)	2
10	90002818	Upper Bar - 10.150" center to center	2
11	70013334	R-Joint Spacers	14
12	70013049	Inner Upper Bar Tab - Driver	1
13	70013050	Inner Upper Bar Tab - Passenger	1
14	70013051	Outer Upper Bar Tab	2
15	70013052	Axle Tab Rear Brace	2
16	90001624	Aluminum Lower Shock Mount	2
17	70002825	Lower Shock Stud	2
18	90002067	Lower Shock Spacers	4
	99752004	RH 3/4"-16 Jam Nut (installed on bar ends)	2
	85000008	Riv-Nut Installation Tool (NOT SHOWN)	1
	70010694	Bar Tab Setting Jig (NOT SHOWN)	2
	99371050	3/8"-16 x 1 1/2" Conical Body Bolt (NOT SHOWN)	6
	99372009	3/8"-16 U-Nut (NOT SHOWN)	6
R-Joint Components - (Installed in bar ends)			
	70013279	Retaining Ring	6
	70013280	Wavo Wave Spring	6
	70013275	R-Joint Center Ball	6
	70013276	R-Joint Composite Center Ball Cage	6

New R-Joints will be quite stiff (75-90 in/lbs breakaway torque) until they "break in" after a few miles of use. After the break in period they will move much more freely. Because the composite bearing race contains self lubricating ingredients, no additional lubrication is needed or desired. Any additional lubrication will only serve to attract more dirt and debris to the R-Joint and actually shorten its life.



Major ComponentsIn the box

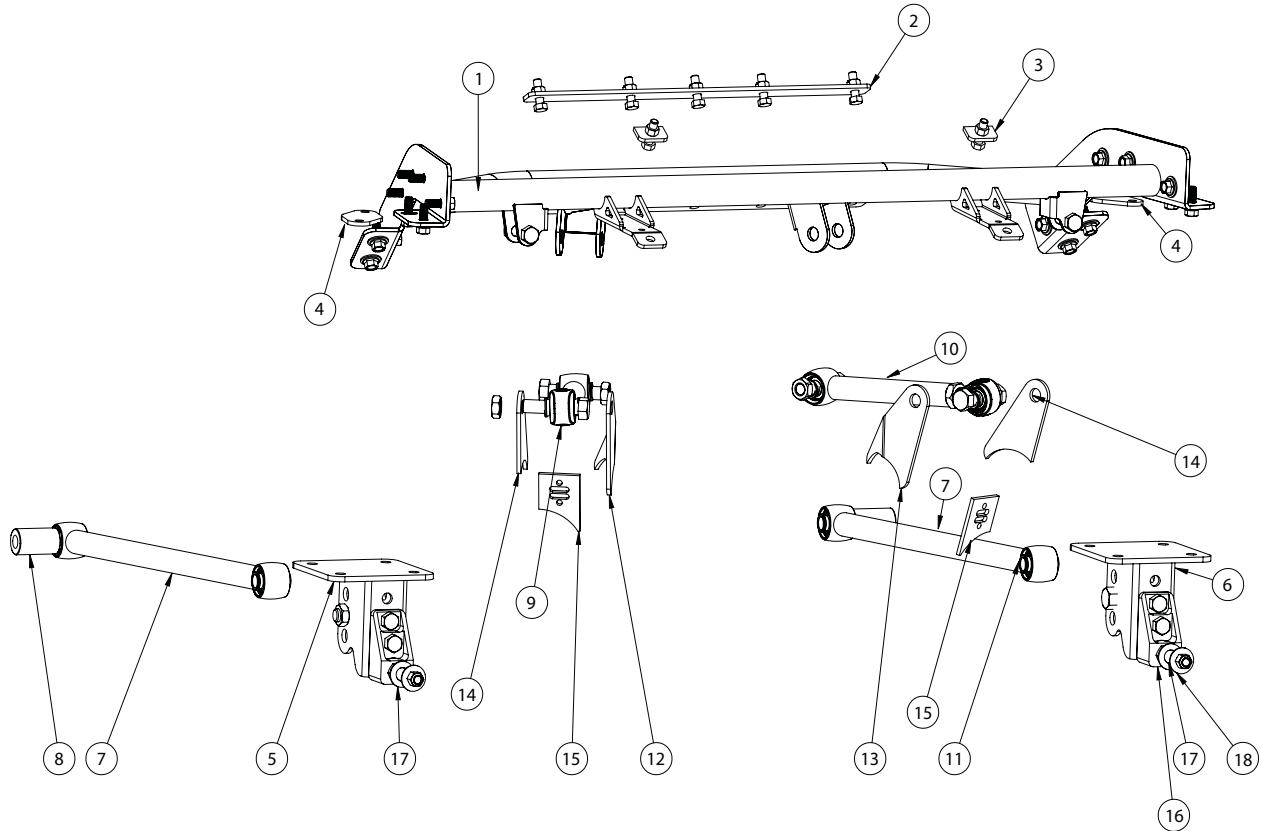

R-JOINT SPACER INSTALLATION

Install the Spacers by inserting the SMALL side of the SPACER into the Center Pivot Ball. Push them in until they bottom out and stop.

LOWER FRONT R-JOINT

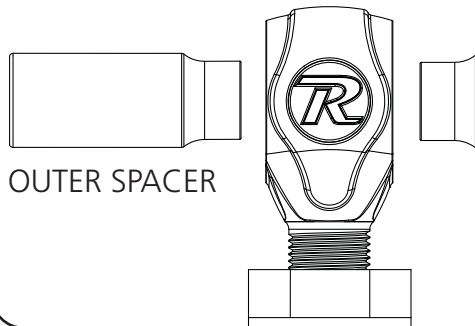

ALL OTHER R-JOINTS

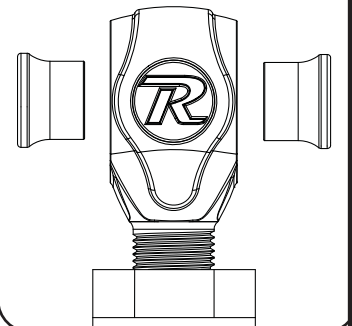

New R-Joints will be quite stiff (75-90 in/lbs breakaway torque) until they "break in" after a few miles of use. After the break in period they will move much more freely. Because the composite bearing race contains self lubricating ingredients, no additional lubrication is needed or desired. Any additional lubrication will only serve to attract more dirt and debris to the R-Joint and actually shorten its life.



Hardware ListIn the box (Kit# 99010197)

The Hardware Kit contains bags to help aid in selecting the correct hardware for the component being installed. The hardware list shows how the hardware is bagged.

QTY	Part Number	Description	QTY	Part Number	Description
CRADLE - FRONT TAB & SWAY BAR MOUNT			4 LINK BARS		
7	99371004	3/8"-16 x 1 1/4" Hex Bolt	6	99621004	5/8"-18 x 3" Gr. 8 Bolt
7	99372002	3/8-16" Nylok Nut	6	99622006	5/8"-18 Nylok Jam Nut
12	99373003	3/8" SAE Flat washer	12	99623010	5/8" SAE Flat Washer
CRADLE MOUNTING			SHOCK MOUNT & SHOCK MOUNTING		
18	99371005	3/8"-16 x 1 1/4" Bolt	2	99501026	1/2"-13 x 2 1/4" Hex Bolt
18	99372007	3/8"-16 Riv-Nut	2	99502007	1/2"-13 Thin Nylok Jam Nut
18	99373006	3/8" Split Lock Washer	2	99501019	1/2"-13 x 1 1/4" Hex Bolt
18	99373002	3/8" SAE Flat washer	2	99501046	1/2"-13 x 1 3/4" Hex Bolt
1	85000007	17/32" Drill Bit	4	99502001	1/2"-13 Nylok Nut
LOWER BAR MOUNT TO AXLE			LOWER BAR - FRONT MOUNTING		
8	99432007	7/16"-20 Nylok Nut	2	99621007	5/8"-18 x 5" Hex Bolt
LOWER BAR - FRONT MOUNTING			2	99622006	5/8"-18 Nylok Jam Nut
2	99621007	5/8"-18 x 5" Hex Bolt	4	99623001	5/8" Flat Washer
2	99622006	5/8"-18 Nylok Jam Nut	UPPER 4 LINK TAB SETTING JIG		
4	99623001	5/8" Flat Washer	2	99371001	3/8"-16 x 3/4" Hex Bolt
SHOCK STUD			2	99372004	3/8"-16 Hex Nut
2	99432002	7/16"-20 Nylok Nut			
2	99433002	7/16" SAE Flat Washer			
2	99623004	5/8" SAE Flat Washer			

Getting Started.....

Congratulations on your purchase of the Ridetech Rear 4-link System. This system has been designed to give your Camaro excellent handling along with a lifetime of enjoyment. This kit replaces the Leaf Springs, this allows the 4-Link to locate the rearend and the CoilOvers/ShockWaves to support the car. This allows each to be optimized for the best performance.

Note: These system is designed for use with the Ridetech Shockwaves or CoilOvers and the MuscleBar swaybar. **The factory shocks and springs will not fit this setup.**

1. Raise the vehicle to a safe and comfortable working height. Use jack stands to support the vehicle with the suspension hanging freely. You will need a method of raising and lowering the differential.
2. Support the axle and remove the leaf springs, shocks, and tail pipes. Refer to the factory service manual for proper disassembly procedures. Retain the front leaf spring mounts, they will be used with the 4 link. You may need to detach the fuel line from the frame rails. The back seat of the car will also need removed for installation of the 4 link cradle.



OEM Variation

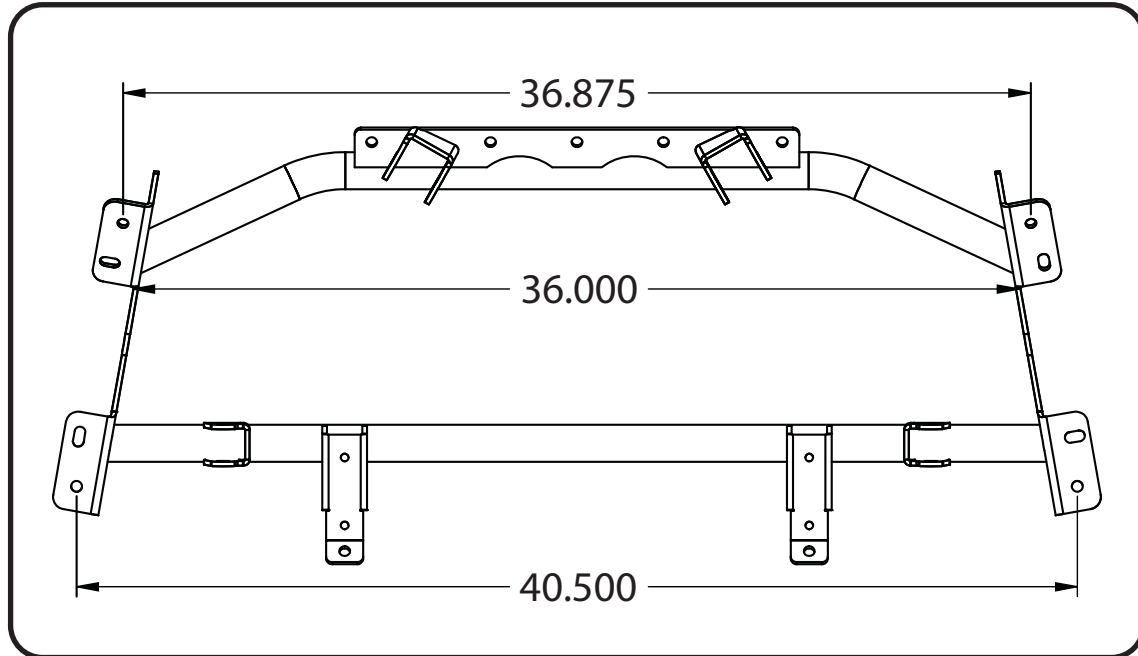

Note: In rare cases, the dimension from frame rail to frame rail on your F-Body may vary from the dimension on the Ridetech Upper Cradle. **ALL** of the Ridetech Upper Cradles are jig built to the dimensions above. The variation in OEM manufacturing specs does happen and is out of our control. If your F-Body frame rails seem out of spec, feel free to contact our Tech Department at 812-482-2932 and we will try to offer some solutions.

Cradle Installation

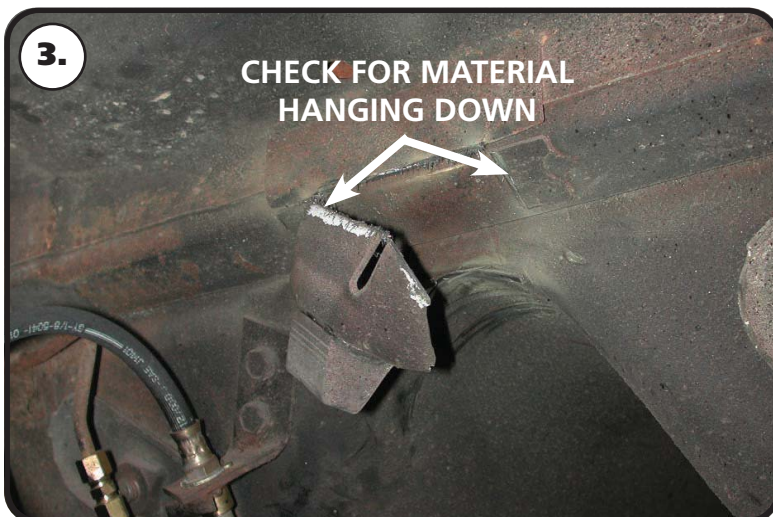

3. Remove the factory pinion snubber and mount from the car, this is necessary for clearance of the upper cradle. We use a cut off wheel to remove the mount. Make sure the area where the ARROW is pointing has no material sticking down. The tabs that are against the body can remain. Check both sides where the snubber mount attached to the body.



Cradle Installation



4. Steps 5-14 cover mounting the cradle into the car, review all steps. Image 4 shows the cradle installed in the car.

Note: The OEM fuel line will need to be detached from the frame rails until the cradle is installed.



5. Install the cradle into the car. When the cradle is positioned properly, the front bar should be up against the body, the front tab will be up against the bottom side of the seam, and the sway bar mount tabs should be up against the bottom of the trunk pan.

THE CRADLE WILL GET TEMPORARILY BOLTED IN BY THE FRONT TAB AND REAR SWAY BAR TABS. IT WILL GET REMOVED TO DRILL AND INSTALL THE RIV-NUTS IN THE FRAME RAILS.



6. Image 6 shows how the front tab overlaps the body seam. Multiple pieces of the car body overlap at this joint making it a strong area to attach to. Drill these 5 holes with a 3/8" drill bit using the cradle as a template.



Cradle Installation



7. The kit includes a backing plate for the front tab. This backing plate is installed in the inside of the car. The rear seat will need removed for installation. Lay the backing plate on the seam, lining up the 5 holes drilled in the previous step. Install a 3/8" flat washer on each of (2) 3/8"-16 x 1 1/4" hex bolts. **Insert a bolt/washer in the 2 other holes from the BOTTOM with the threads pointing up.** Install a 3/8" flat washer followed by a 3/8"-16 nylok nut on threads of each of the bolts sticking through the backing plate.



8. Drill a 3/8" hole through the each of the sway bar mount tabs. These holes will go into the trunk so make sure nothing is in the trunk floor. If there is a mat, remove it before drilling the holes.

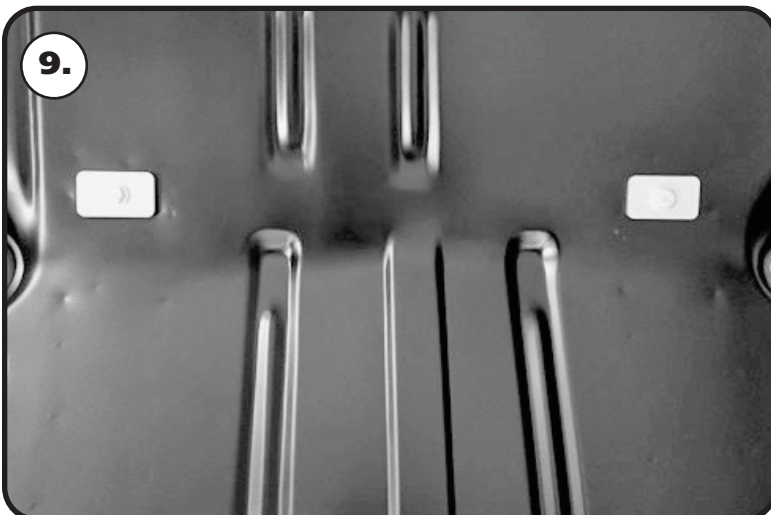

9. Image 9 shows the trunk backing plates installed in the trunk. Locate the backing plates in the trunk lining up the center hole with the hole drilled in the floor. Install a 3/8" flat washer on each of (2) 3/8"-16 x 1 1/4" hex bolts. Insert the bolt/washer through the backing plate, through the trunk floor and sway bar Tab with **the threads on the Bolt pointing DOWN.** Install a 3/8" flat washer followed by a 3/8"-16 nylok nut on the threads of the bolts sticking through the sway bar tab.



Riv-nut® Installation & Specs

1. Drill hole in frame using the SUPPLIED DRILL BIT keeping the drill square with the metal.
2. We recommend installing (2) 3/8" flat washers between the bolt head and the lower anvil of the installation tool. Thread a Riv-nut® onto the supplied Tool. Thread the Riv-nut all the way onto the tool until it stops.
3. Insert the tool and Riv-nut® into the drilled hole 90° to the frame rail.
4. The tool requires (1) 9/16" & (1) 5/8" wrenches to use. A ratchet can be used on the top of the tool.

KEEP THE TOOL AND RIV-NUT 90° TO THE SURFACE WHILE TIGHTENING

5. Put a 5/8" wrench on the lower hex of the tool. Use a wrench or ratchet on the top hex to tighten.
6. Hold the wrench in one position and turn the TOP HEX CLOCKWISE to engage the Riv-nut®. Keep turning the TOP WRENCH until you feel a positive stop and you can't turn the TOP WRENCH anymore.
7. Break the tool loose by turning the TOP HEX counterclockwise and thread the tool out of the Riv-nut®

THE DATA BELOW ILLUSTRATES THE STRENGTH OF THE RIV-NUT®

RIVNUT® Fastener Engineering Data

Upset Load (lbs.)		
RIVNUT * Size	Steel	
	Min. Grip	Max. Grip
3/8-16	4965	5325

Fig. 1

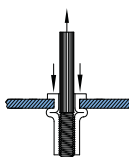

Ultimate thread strength (lbs.)		
RIVNUT * Size	Steel	
	Min. Grip	Max. Grip
3/8-16	11500	10450

Fig. 2

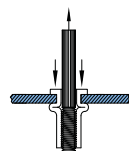

Ultimate tensile strength (lbs.)	
RIVNUT * Size	Steel
3/8-16	3900

Fig. 3

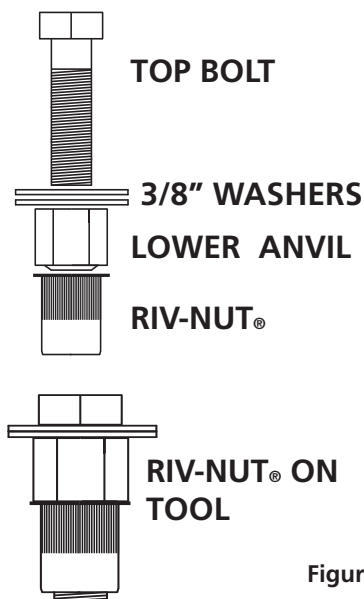
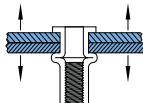

Figure 2

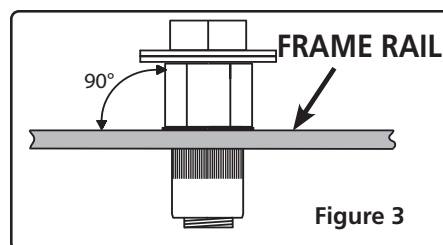

Figure 3

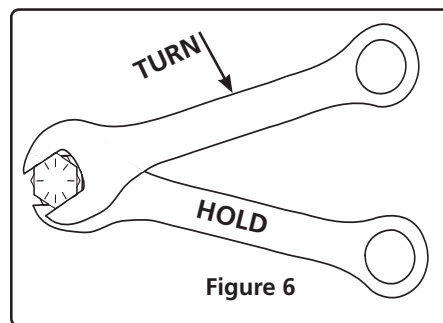

Figure 6

**Single Shear Strength 3/8" Grade 5 Bolt
3,975.8 lbs**



Cradle Installation



10. Mark the holes of the frame mounts. Mark the slotted holes in the center of the slot. These holes use Riv-nuts to bolt the cradle to the frame. The holes need to be centered as much as possible. Make sure to mark all (9) holes in each frame rail.



11. Remove the cradle to drill the holes and install the Riv-nuts. The holes for the Riv-nuts **NEED** to be drilled with the supplied 17/32" drill bit. We suggest drilling the holes with a smaller drill bit first to make it easier to drill with the 17/32" drill bit. Drill all (18) holes in the frame rails.



12. Install the Riv-nuts in the frame rails. **Refer to the Riv-nut installation instructions on PAGE 8 for proper Riv-nut installation.** **Image 12** illustrates a Riv-nut being installed. Install all (18) Riv-nuts in the frame rails.



Cradle Installation & Lower Bar Mount



13. After you get all the riv-nuts installed, reinstall the cradle in the car. The bolts for the front tab and sway bar mounts can be reinstalled. Leave everything loose until all the bolts are started.



14. Install a 3/8" split lock washer & 3/8" flat washer on each of the 3/8"-16 x 1 1/4" bolts supplied in the kit. Thread them into the riv-nuts. Torque to 23 ft-lbs. Torque the front tab and sway bar tab hardware to 30 ft-lbs.



15. The R-joint setup is designed to be offset to the inside of the car. The bolt hole in the mounting bracket has to be drilled out to 5/8" and the new 5/8" x 5" bolt, washers, & 5/8" thin nylok nut are used. The wider spacer is used on the outside with a narrow spacer on the inside. This will offset the bar to the inside of the car for better wheel and tire clearance. The bolt needs to go in the bracket like seen in the picture. The threads of the bolt must be pointing to the OUTSIDE of the car. Shown in **Image 15** is the driver side bar and mount. Repeat on both sides and tighten the bolts/nuts enough to eliminate any gaps.



Lower Bar & Shock Mount Installation



16. Attach the lower bar/mount assembly to the car. New 3/16"-16 u-nuts and 3/8-16" x 1 1/2" conical body Bolts are supplied in the kit. Install the u-nuts in place of the OEM u-nuts. Hold the assembly in place lining up the holes with the u-nuts. There is a tab bent up on the mount that indexes into a hole in the body. Make sure the tab is indexed into the alignment hole.

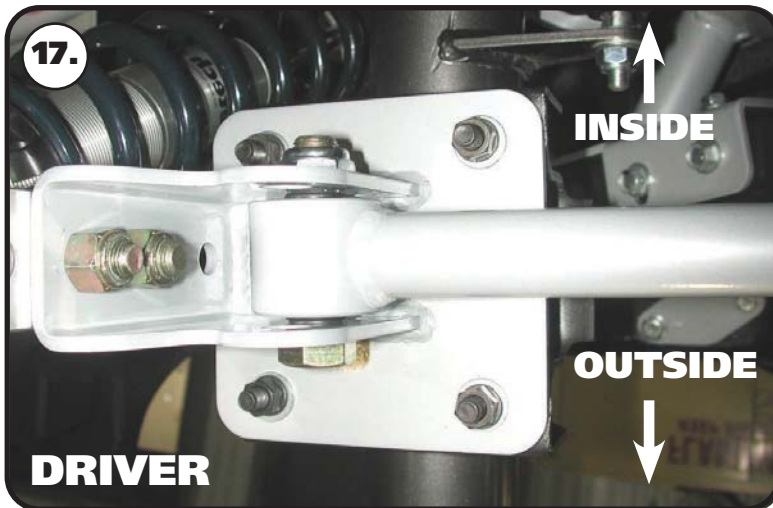

17. The lower axle bracket will be fastened to the leaf spring pad using the factory T-bolts/ U-bolts. The bar mount is offset to the inside of the car to provide more wheel and tire clearance. New 7/16" nyloks are supplied. Torque the nuts to 55 ftlbs.

Image 17 shows the Driver side.

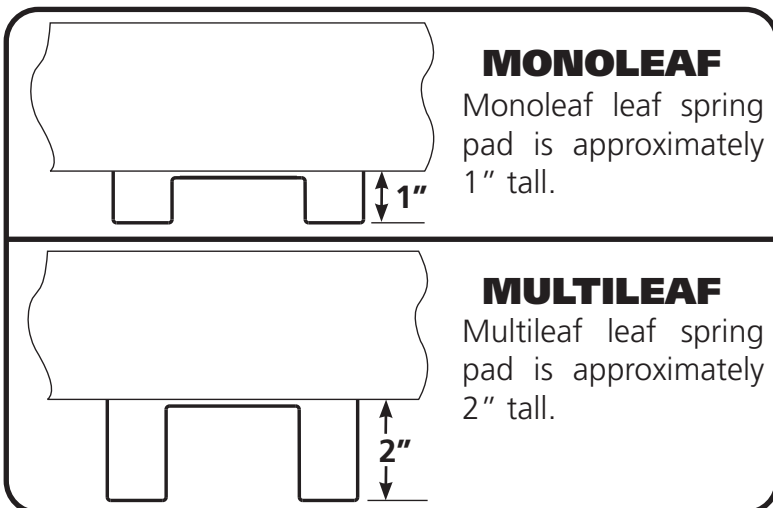

The 67-69 F-body could come with either a **Monoleaf spring** or **Multileaf spring**. We provided this guide to help you determine which leaf spring mount your car has. **Steps 18 & 19** cover bolting the lower shock mount to the axle bracket. You need to know which leaf spring mounts you have to determine how the shock mount needs bolted to the axle mount. **Image 18** shows the Multileaf, **Image 19** covers the Monoleaf. The leaf spring mount on each of the rear differentials are different heights requiring the lower shock mount be attached in different locations depending on the leaf spring mount. The lower mount attaches with (1) 1/2"-13 x 1 1/4" hex bolt, (1) 1/2"-13 x 1 3/4" Hex Bolt, & (2) 1/2"-13 nylok nut.



Attaching Lower Shock Mount & Lower Bar

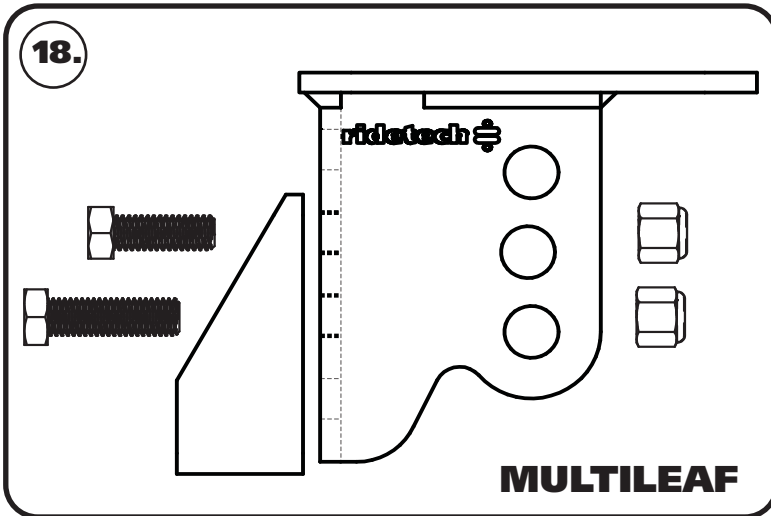

18. MULTILEAF - The Multileaf setup uses the **MIDDLE 2 HOLES** for mounting. Insert the bolts through the aluminum shock mount with the 1 1/4" long bolt in the top bolt, 1 3/4" in the bottom hole. Insert the bolts through the axle mount and install the nylok nuts on the threads sticking through. Repeat on both sides and torque the bolts/nuts to 75 ftlbs. Skip to **Step 20**.

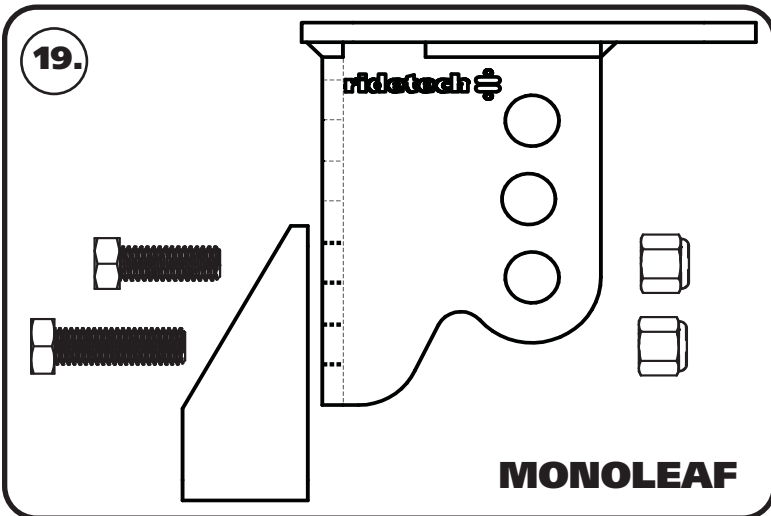

19. MONOLEAF - The Monoleaf setup uses the **BOTTOM 2 HOLES** for mounting. Insert the bolts through the aluminum shock mount with the 1 1/4" long bolt in the top bolt, 1 3/4" in the bottom hole. Insert the bolts through the axle mount and install the nylok nuts on the threads sticking through. Repeat on both sides and torque the bolts/nuts to 75 ftlbs.

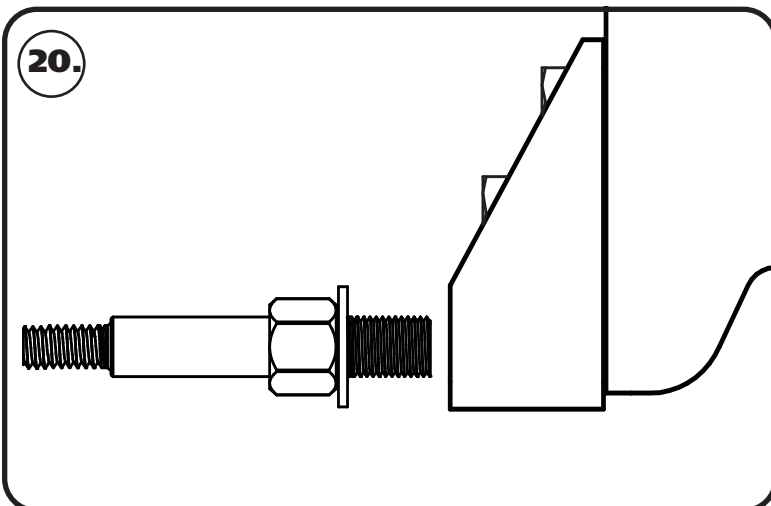

20. Installing the shock stud into the lower mount. Install a 5/8" flat washer onto the 5/8"-18 threads of the shock stud. Apply Red Loctite to the 5/8" threads of the stud. Thread the shock stud into the threaded hole of the lower mount. Repeat on both sides and torque the shock stud to 65-75 ftlbs.



Installing Lower Bar

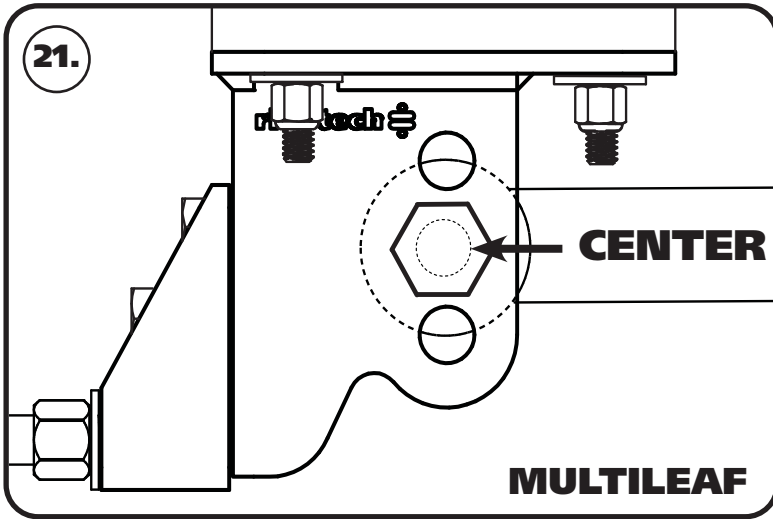

21. Images 21-23 illustrate attaching the lower bar to the axle mount. Image 21 shows the Multileaf, Image 22 covers the Monoleaf, Image 23 shows a bottom view. The different heights of the leaf spring pads of the differentials require the lower bars to be mounted in the correct hole to optimize the geometry of the 4 link bars. A 70013334 spacer will need to be installed on each side of the R-Joint with the SMALL OD inserted into the R-joint center ball. Use **Image 23** as a reference. The lower bar attaches with (1) 5/8"-18 x 3" hex bolt, (2) 5/8" flat washers, & (1) 5/8"-18 nylok jam nut. **MULTILEAF** - The Multileaf setup uses the MIDDLE HOLES for mounting. Insert the bar into the lower mount lining the bushing sleeve up with the CENTER set of holes. Insert a 5/8"-18 x 3" bolt into the hole/sleeve. Install a 5/8"-18 nylok jam nut on the bolt threads sticking out of the bracket. Repeat on both sides and tighten the bolts/nuts enough to eliminate any gaps. Skip to **Step 23**.

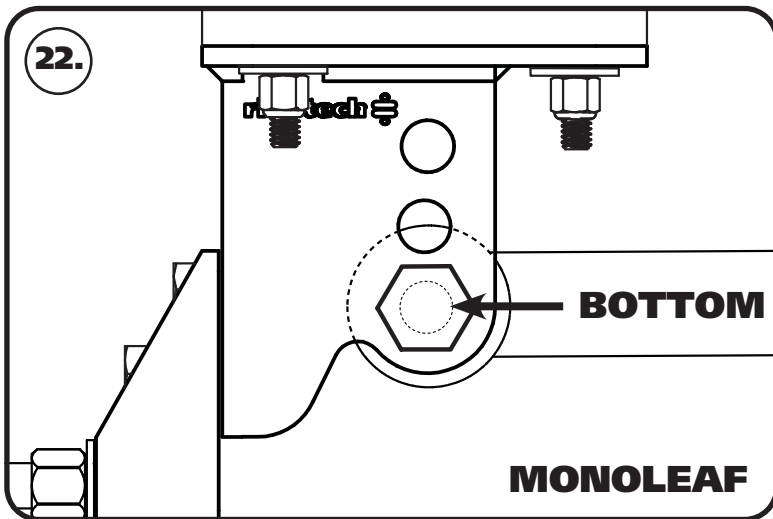

22. MONOLEAF - The Monoleaf setup uses the BOTTOM HOLES for mounting. Insert the bar into the lower mount lining the bushing Sleeve up with the BOTTOM set of holes. Insert a 5/8"-18 x 3" bolt into the hole/sleeve. Install a 5/8"-18 nylok jam nut on the bolt threads sticking out of the bracket. Repeat on both sides and tighten the bolts/nuts enough to eliminate any gaps.



23. Image 23 shows a bottom view of the bar installed. Notice the spacers in each side of the R-Joint.



Setting Pinion Angle

READ PAGES 14-16 ON SETTING RIDE HEIGHT, SETTING PINION ANGLES & UPPER BAR TAB JIG INSTALLATION .

How do you set the pinion angle? On a single-piece shaft you want to set it up where a line drawn through the center of the engine crankshaft or output shaft of the transmission and a line drawn through the center of the pinion are parallel to each other but not the same line.

Your transmission angle should be around 3 degrees down in the rear. If it is more or less than 3 degrees, you might want to consider changing it. Too little angle on the transmission reduces the amount of oil getting to the rear bushing. Too much transmission angle will increase the working angles of the u-joints which will increase the wear. With the transmission at 3 degrees down in the rear, you will want to set the pinion 3 degrees up in the front.

A simple way to do this is to place a digital angle finder or dial level on the front face of the lower engine pulley or harmonic balancer. This will give you a reading that is 90 degrees to the crank or output shaft unless you have real problems with your balancer. At the other end, you can place the same level or angle finder against the front face of the pinion yoke that is also at 90 degrees to the centerline. If you rotate the yoke up or down so both angles match, you have perfect alignment.

Road testing will tell you if you have it right. If you accelerate and you get or increase a vibration, then the pinion yoke is too HIGH. Rotate it downward in small increments of a degree or two until the problem goes away. If you get or increase a vibration when decelerating, then the pinion yoke is too LOW. Rotate it upward to correct it.

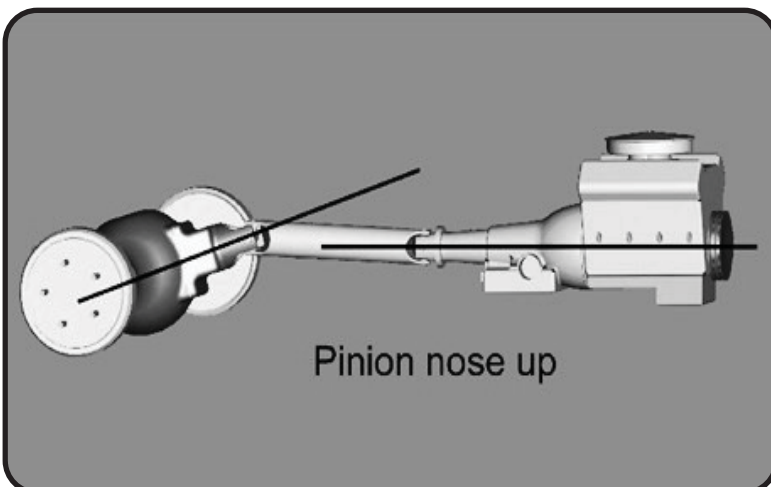
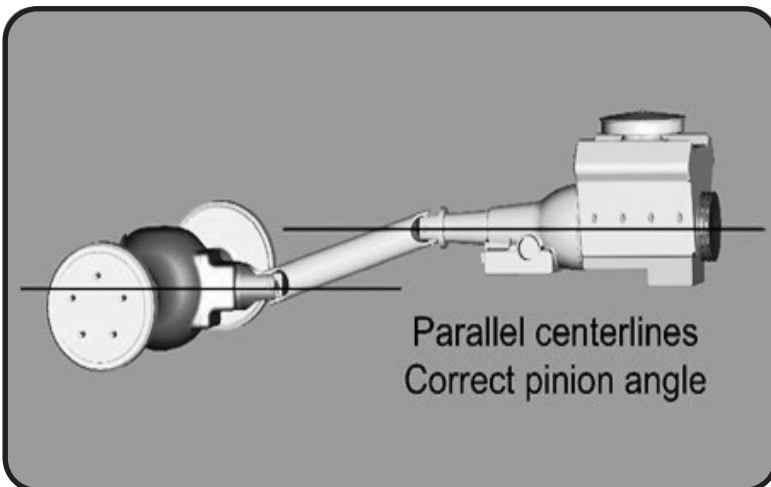
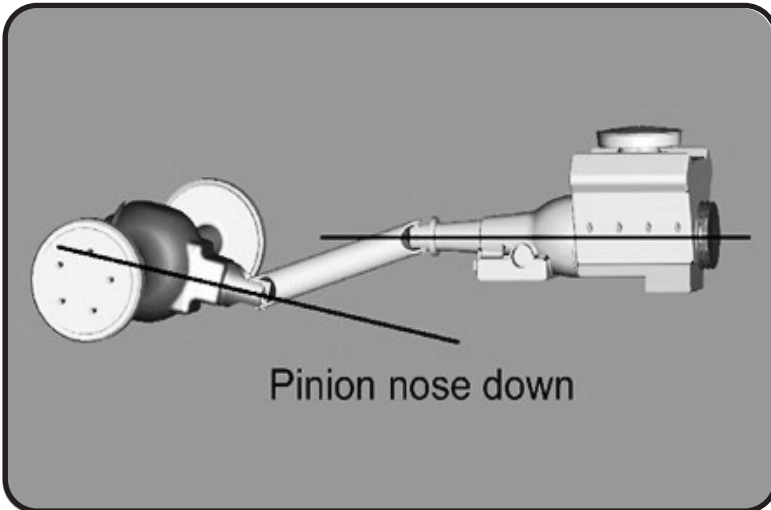



Upper Bar Tab Installation Jig

Upper Bar Installation Jig

- This jig has been supplied to aid in the installation of the upper 4 link bar. It can be temporarily used to properly align, locate and weld the tabs onto the axle. It will also ensure that the mounting bolts are parallel to the ground.
- Follow the diagram below to set the jig to the same length as the upper bar, use the 3/8" x 3/4" bolt and nuts to set the length.
- Position the axle at ride height. Center the axle left to right between the quarter panels. Set pinion angle.
- Bolt one end of the jig to the cradle using a 5/8" x 3" bolt.
- Using another 5/8" x 3" bolt, fasten the axle tabs to the other end. There is a Driver and Passenger Inner Tab. It is bent to keep the tab from hitting the center section of the rear end. It is positioned with the tab bent to the front of the car. The short tab goes to the outside of the car. The tabs must be bolted to the outside of the jig.
- Swing the bar down letting the tabs rest onto the axle. Trim the brackets as necessary to minimize the gap to be welded.
- Check pinion angle, ride height and axle center. Tack-weld the tabs in place and tack-weld the back brace in place. Refer to Images 25 & 26 for position of the back brace.
- Remove jig and install upper bar.
- Repeat this process for the other side.
- Recheck pinion angle, ride height and axle center. (Sound familiar?)
- After the tabs have been tack welded on both sides, remove the upper bars to avoid damaging the rod end. Let the axle drop down for better access to the tabs. Lay 1" welds on the inside and outside of the tabs. Skip around from one side to the other to avoid overheating the tube.

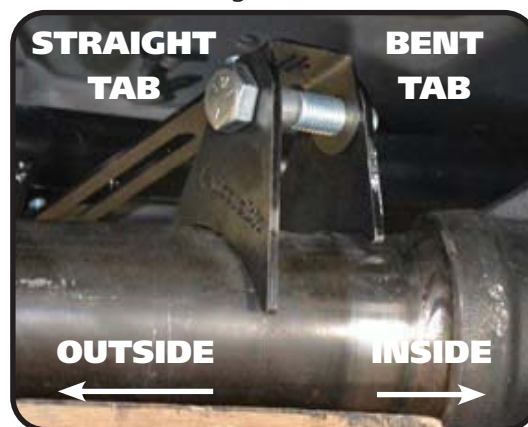
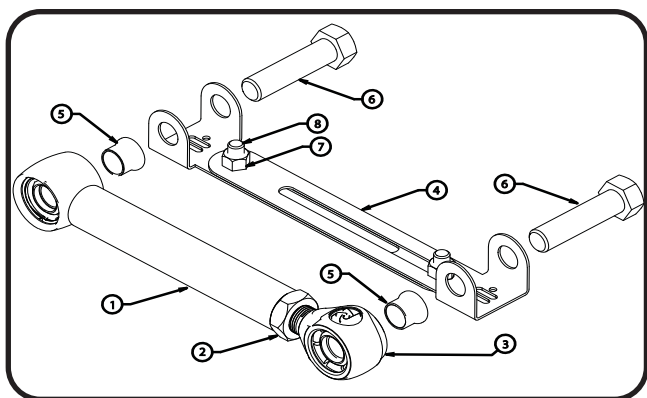

Item#	Description
1	Upper Bar
2	3/4"-16 Jam Nut
3	R-Joint End
4	Alignment Jig
5	Aluminum Spacer
6	5/8" x 2 3/4" Bolt
7	3/8"-16 Nut
8	3/8"-16 x 3/4" Bolt





Installing Axle Tabs



24. One helpful trick to help maintain ride height and pinion angle while adjusting is to tack weld a spacer between the axle and the outside of the frame as shown in the picture. This spacer should be 8 1/2" tall giving the Shockwave an eye-to-eye measurement of approximately 14 1/2". When measuring the axle center you can measure off of the frame rails. We also use a plum bob off the quarter panels to double check the axle center. Refer to **Page 14** on setting the pinion angle.

Note: You can tack weld the spacer in place after you get the pinion angle, and axle center set. This will ensure that nothing moves through the upper tab Installation.

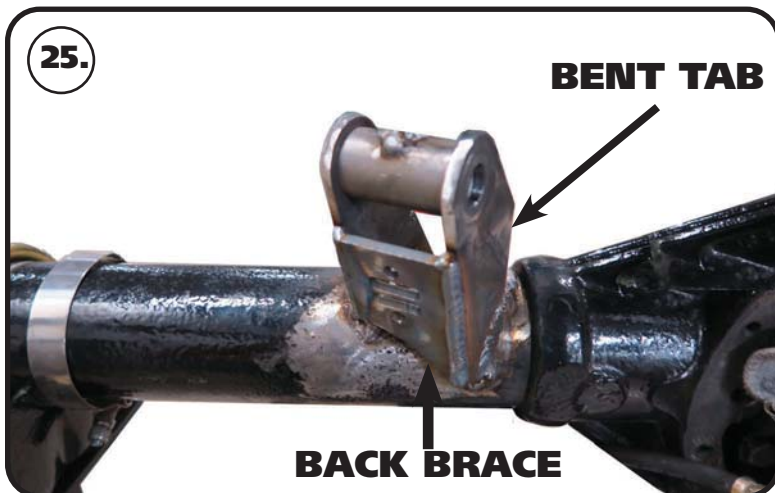

25. Check the length of the upper bar; it should be 10.150" center to center. Bolt the axle tabs to the setting jig as specified on the previous page. straight tab to the outside of the car, bent tab to the inside of the car. The bend needs to be to the front, making the front of the tab run parallel with the cast center section. If they are installed on the incorrect sides, the tab will hit the center section of the axle. Next, place the other end into the cradle. Both ends use a 5/8" x 3" and should not be fully tightened yet. For now just let axle tabs sit on the axle.

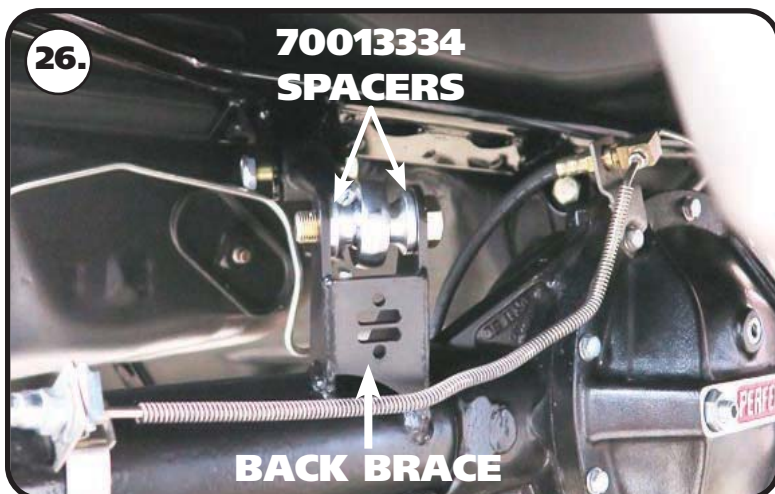

26. Check the fitment of the tabs and tack weld them to the axle. Do this for the Driver and Passenger side bars. Insert the bars into the cradle and tabs to double check fitment. Recheck axle center and pinion angle. Once satisfied with fitment weld the upper bar tabs onto the axle. Weld 1" at a time, skip around from one side to the other, and one tab to the other to avoid overheating the axle tube. When the tabs cool down, install the upper bars using (1) 5/8" x 3" bolt, (2) 5/8" flat washers, and (1) 5/8" Thin nylok nut on each end. Install a 70013334 spacer in each side of the R-joint using **Image 26** as a reference. Repeat on both sides and tighten the bolts/nuts enough to eliminate any gaps.



Installing Shockwaves/Coilovers & Shock Block Off

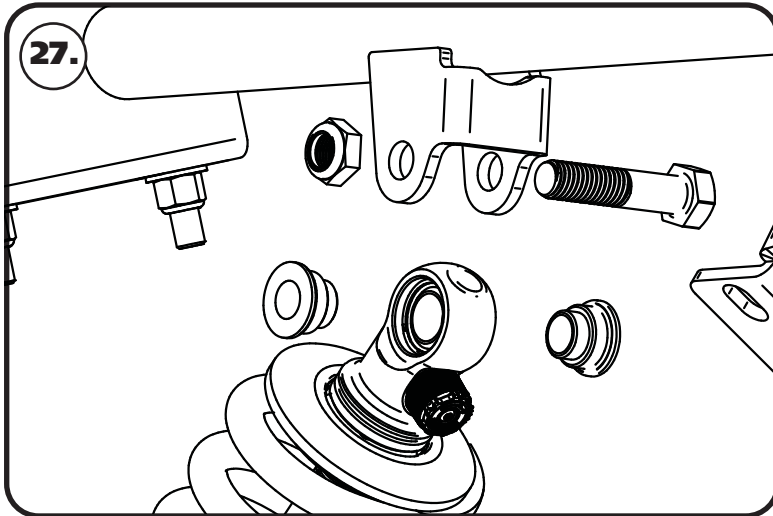

Remove the Spacer from between the Axle and Frame.

27. Install a 1/2" ID 90002043 spacer on each side of the upper Coilover/ShockWave. Slide the assembly into the upper crossmember from the bottom side. Position the adjuster knob so that the knob points toward the center of the car. Line up the hole in the spacers with the hole in the upper shock bridge and insert 1/2"-13 x 2 1/4" bolt and install 1/2"-13 Thin Nylok nut.

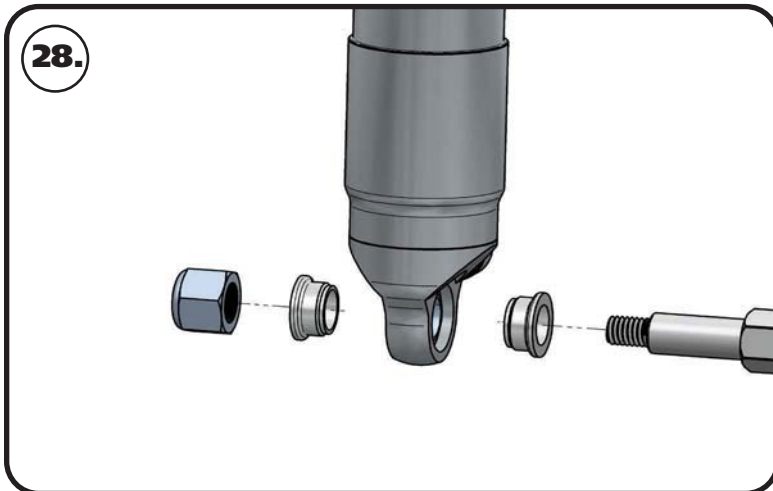

28. Install a 5/8" ID 90002067 spacer (**Small side towards shock body**) onto the lower Shock Stud. Slide the bottom of the Shock onto the Stud. Install a second 5/8" ID 90002067 Spacer onto the Stud (**small side towards shock**). You may need to jack the rearend up to Slide the Shock onto the Stud. Install the 7/16" Flat washer and 7/16" Nylok nut. Tighten the upper and lower shock bolts. Torque the Upper Bolt to 55 ftlbs and the Lower Nut to 40 ftlbs. The designed ride height of the CoilOver/Shockwave is 14 1/2" center to center.

Note: If installing Shockwaves and you want to locate the air fitting in a different location, the air spring assembly can be rotated on the shock by grabbing the air spring assembly by hand and spinning it on the shock.



29. Bolt the Shock Block Off Plates in place of the OEM upper shock mounts using the OEM hardware. If you are running Mini Tubs, these mounts do not exist any more.



Part # 21150701 - 5.2" Stroke HQ Series Shockwave

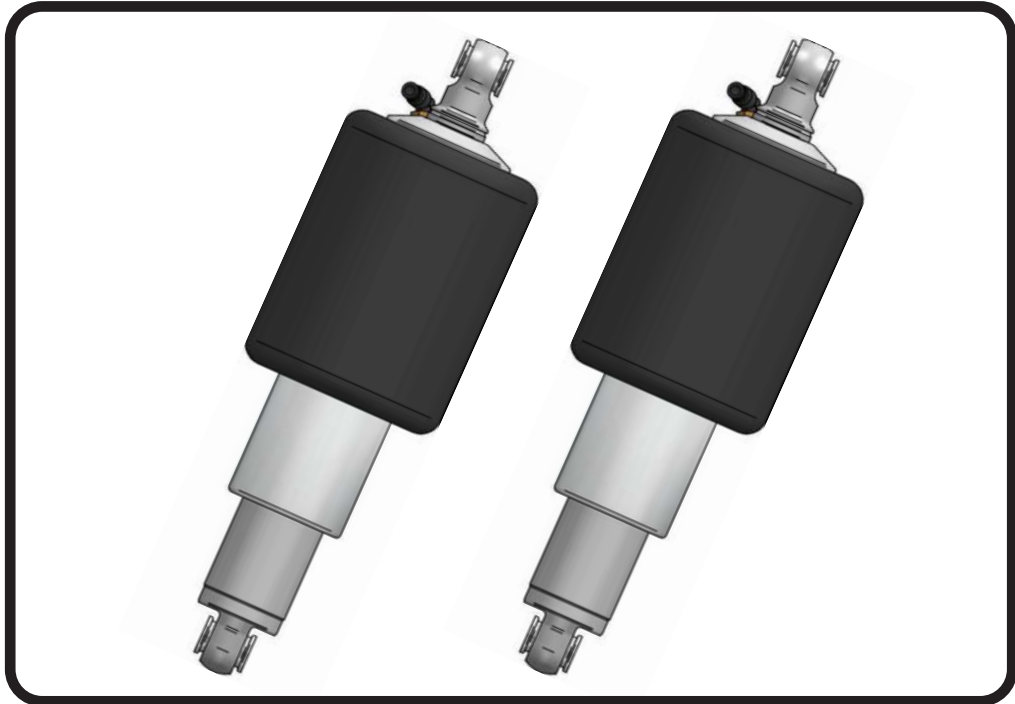

Recommended Tools

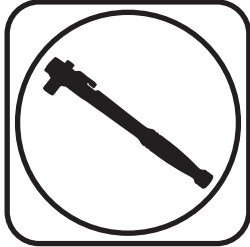

7000 Series Bellow, Eye/Eye 5.2" Shock Installation Instructions

Table of contents

Page 42..... Included Components

Page 43..... Notes and Care of Your Shockwave

Page 44..... Shock Adjustment

ShockWave Dimensions:

Center of bearing to Center of bearing:	
Compressed:	11.85"
Ride Height:	14.60"
Extended:	16.42"



Major ComponentsIn the box

Item #	Part #	Description	QTY
1	982-10-805	5.2" Stroke HQ Series Shock	2
2	815-05-022	Shock Eyelet	2
3	24090799	7000 Series, 4" Diameter AirSpring	2
4	234-00-153	AirSpring Locking Ring (Installed on Shock)	2
5	90002044	Spacer kit - 1/2" ID and 5/8" ID	4
	90001994	5/8" ID Bearing (installed in shock and eyelet)	4
	90001995	Bearing Snap Ring (installed in shock and eyelet)	8

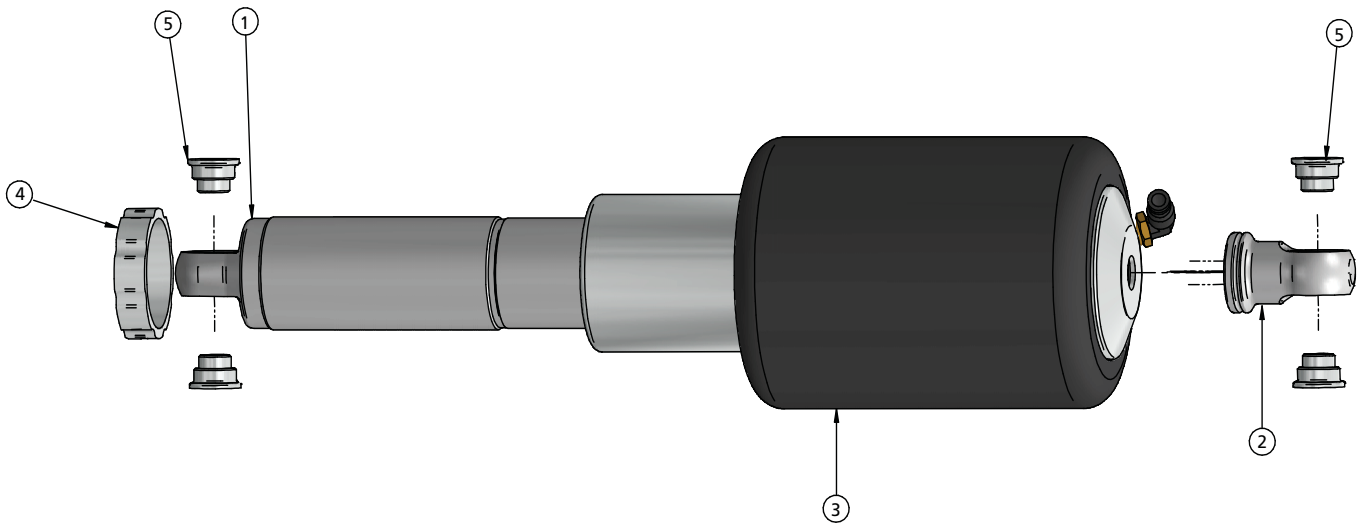

WARNING: ATTEMPTING TO REMOVE THE AIR FITTING WILL DAMAGE IT AND VOID THE WARRANTY.



Notes and Care of your Shockwaves

NOTES:

WARNING: ATTEMPTING TO REMOVE THE AIR FITTING WILL DAMAGE IT AND VOID THE WARRANTY.

TIGHTENING THE TOP 9/16"-18 NUT: SNUG THE NUT DOWN AGAINST THE TOP CAP. YOU NEED TO BE ABLE TO ARTICULATE THE SHOCK BY HAND. WE TORQUE THE NUT TO 80 INLBS USING A 7/8" CROWS FOOT WRENCH ON A TORQUE WRENCH.

You can clock the airfitting location on the ShockWave by turning the AirSpring assembly of the shock. Make sure the fitting doesn't contact the frame.

When cutting the airline, use a razor blade. The cut needs to be a clean cut and square for the airline to seal properly.

The Locking ring on the shock is NOT adjustable. These rings are set at the factory to optimize the AirSpring stroke with the shock stroke.

The care and feeding of your new ShockWaves

1. Although the ShockWave has an internal bumpstop, **DO NOT DRIVE THE VEHICLE DEFLATED RESTING ON THIS BUMPSTOP. DAMAGE WILL RESULT.** The internal bumpstop will be damaged, the shock bushings will be damaged, and the vehicle shock mounting points may be damaged to the point of failure. This is a non warrantable situation.
2. Do not drive the vehicle overinflated or "topped out". Over a period of time the shock valving will be damaged, possibly to the point of failure. This is a non warrantable situation! If you need to raise your vehicle higher than the ShockWave allows, you will need a longer unit.
3. The ShockWave is designed to give a great ride quality and to raise and lower the vehicle. **IT IS NOT MADE TO HOP OR JUMP!** If you want to hop or jump, hydraulics are a better choice. This abuse will result in bent piston rods, broken shock mounts, and destroyed bushings. This is a non warrantable situation.
4. Do not let the ShockWave bellows rub on anything. Failure will result. This is a non warrantable situation.
5. The ShockWave product has been field tested on numerous vehicles as well as subjected to many different stress tests to ensure that there are no leakage or durability problems. Failures have been nearly nonexistent unless abused as described above. If the Shockwave units are installed properly and are not abused, they will last many, many years. ShockWave units that are returned with broken mounts, bent piston rods, destroyed bumpstops or bushings, or abrasions on the bellows will not be warrantied.



Shock Adjustment

Shock adjustment 101- Single Adjustable

Rebound Adjustment:

How to adjust your new shocks.

The rebound adjustment knob is located on the top of the shock absorber protruding from the eyelet.

You must first begin at the ZERO setting, then set the shock to a soft setting of 20.



-Begin with the shocks adjusted to the ZERO rebound position (full stiff). Do this by rotating the rebound adjuster knob clockwise until it stops.



-Now turn the rebound adjuster knob counter clock wise 20 clicks. This sets the shock at 20. (settings 21-24 are typically too soft for street use).

Take the vehicle for a test drive.



-if you are satisfied with the ride quality, do not do anything, you are set!

-if the ride quality is too soft increase the damping effect by rotating the rebound knob clock wise 3 clicks. **CONTINUE ON NEXT PAGE.**

Take the vehicle for another test drive.



-if the vehicle is too soft increase the damping effect by rotating the rebound knob clock wise 3 additional clicks.



-If the vehicle is too stiff rotate the rebound adjustment knob counter clock wise 2 clicks and you are set!

Take the vehicle for another test drive and repeat the above steps until the ride quality is satisfactory.

Note:

One end of the vehicle will likely reach the desired setting before the other end. If this happens stop adjusting the satisfied end and keep adjusting the unsatisfied end until the overall ride quality is satisfactory.