



Part # 11230298 - 1964-1967 GM "A" Body HQ ShockWave System

Recommended Tools

Front Components:

11233001	Front ShockWaves
11222899	Front Lower StrongArms
11223699	Front Upper StrongArms
11009310	Ridetech Tall Spindle
11239120	Front SwayBar

Rear Components:

11236699	Rear Upper StrongArms
11224499	Rear Lower StrongArms
11227299	Axle R-Joint & Installation Tool
11225401	Rear ShockWaves
11239122	Rear SwayBar

Miscellaneous Components:

85000000	Spanner Wrench
----------	----------------

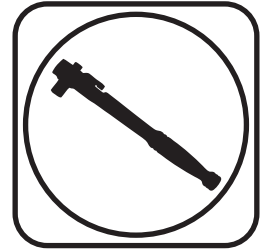

1964-1967 GM "A" Body Air Kit Installation Instructions

Table of contents

Pages 2-5.....	Front ShockWaves
Pages 6-9.....	Front Lower StrongArms
Pages 10-15.....	Front Upper StrongArms
Pages 16-19.....	Tall Spindle
Pages 20-22.....	Front SwayBar
Pages 23-25.....	Rear Upper StrongArms
Pages 26-28.....	Rear Lower StrongArms
Pages 29-33.....	Front Axle Housing R-Joint & Tool
Pages 34-40.....	Rear ShockWave Kit
Pages 41-44.....	Rear SwayBar





Part # 11233001 - 64-67 GM A-Body Front HQ Series Shockwave

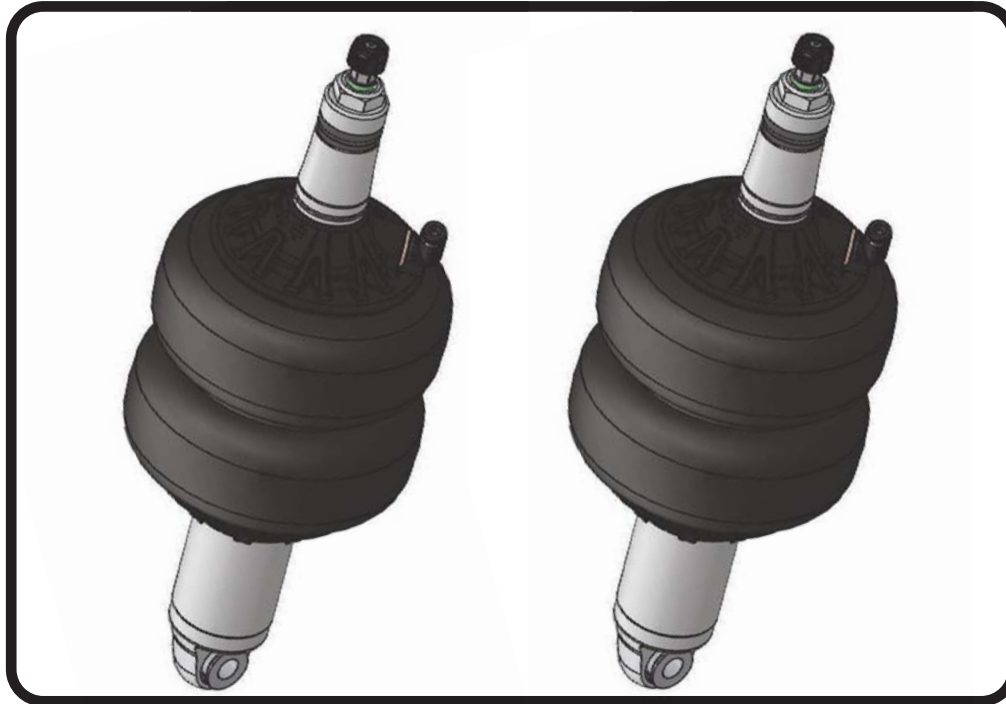

Recommended Tools

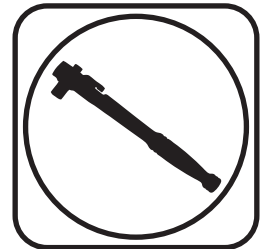

1000 Series Bellow, 3.75" Stud/Eye 4.1" Shock Installation Instructions

Table of contents

Page 3..... Included components

Page 4-5..... Shockwave Installation

ShockWave Dimensions:

Center of bearing to Center of bearing:

Compressed: 12.75"

Ride Height: 14.50"

Extended: 16.25"

THE DELRIN BALL REQUIRES A 3/4" HOLE FOR THE FLANGE TO GO THROUGH. THIS CAN BE DRILLED WITH A UNIBIT.





Major ComponentsIn the box

Item #	Part #	Description	QTY
1	982-10-804	4.1" Stroke HQ Series Shock	2
2	90009993	3.75" Stud Top (Installed on Shock) - Includes Adjuster Knob & Screw	2
3	24090199	1000 Series 6.5" Double Convoluted AirSpring	2
4	234-00-153	AirSpring Locking Ring (Installed on shock)	2
5	99055000	Locking Ring Set Screw (Installed on shock)	2
6	90002062	Spacers - INCLUDED WITH STRONGARMS	4
7	90002314	3.75" Aluminum Stud Top Base	2
8	90001904	Bottom Delrin Ball	2
9	90001903	Top Delrin Ball	2
10	90001902	Delrin Ball Aluminum Top Cap	2
11	99562003	9/16" -18 Thin Nylok Nut	2
12	210-35-120-0	Adjuster Knob - (90009993 assembly)	2
13	90009969	#4-40 X 1/4" SS, 18-8 Pan Head Torx Cap - (90009993 assembly)	2
	70012162	3.75" Stud Top Metering Rod (installed in stud top)	2
	90001994	5/8" ID Bearing (installed in shock and eyelet)	4
	90001995	Bearing Snap Ring (installed in shock and eyelet)	8

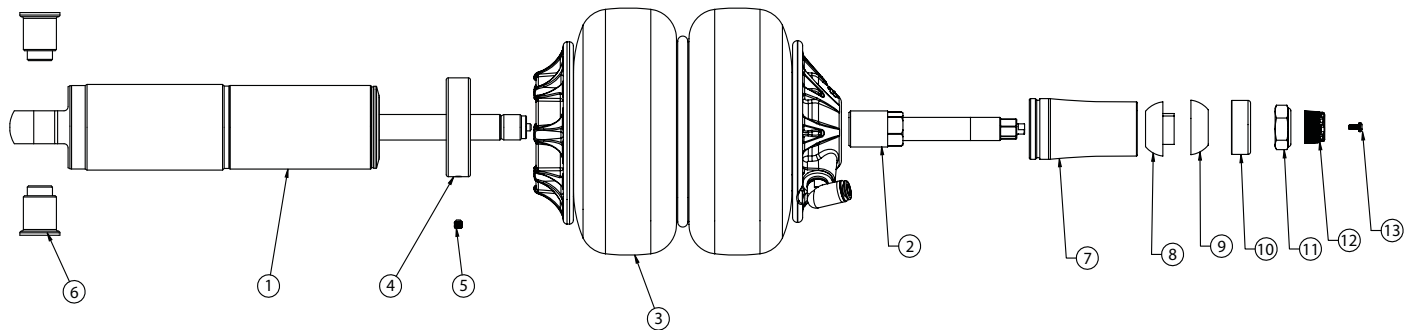

THE DELRIN BALL REQUIRES A 3/4" HOLE FOR THE FLANGE TO GO THROUGH. THIS CAN BE DRILLED WITH A UNIBIT.

WARNING: ATTEMPTING TO REMOVE THE AIR FITTING WILL DAMAGE IT AND VOID THE WARRANTY.



ShockWave Installation

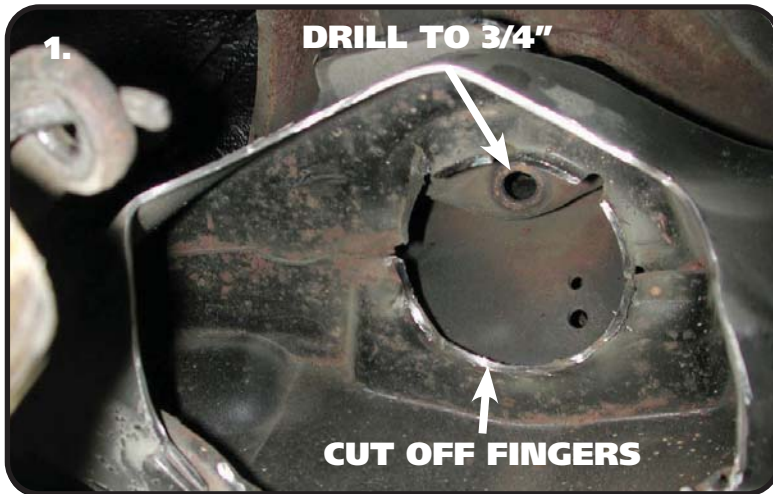

1. Drill the OEM shock hole out to 3/4". This can be done with a Unibit. The Shockwave top can come in contact with the coil spring retaining fingers. Test fit the ShockWave to determine if they need cut off. A die grinder works well here.



2. Some trimming must also be done on the outside of the frame pocket to allow clearance for the Shockwave.



3. To allow clearance for the Shockwave, some trimming must be done on the inside of the coil spring pocket as shown by the white line in the picture. This is best done with either a cut off wheel or plasma cutter. Grind all cuts smooth when finished.

Note: It may be helpful to go ahead and install the lower StrongArms and Shockwaves to determine exactly what needs to be removed.



ShockWave Installation

4.

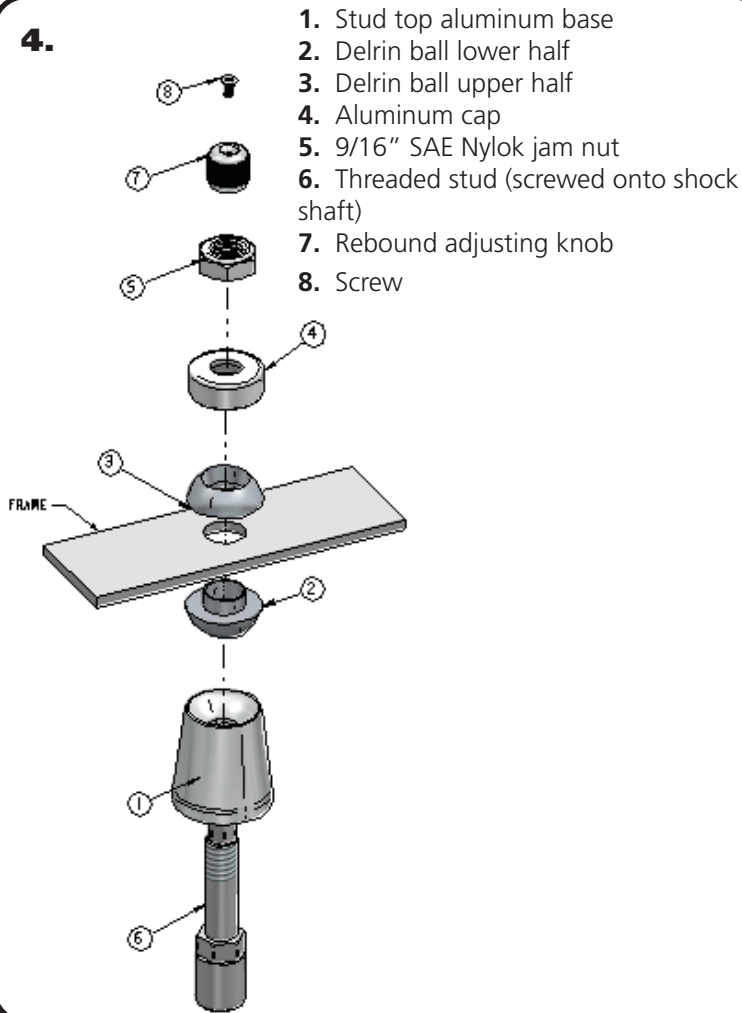

1. Stud top aluminum base
2. Delrin ball lower half
3. Delrin ball upper half
4. Aluminum cap
5. 9/16" SAE Nylok jam nut
6. Threaded stud (screwed onto shock shaft)
7. Rebound adjusting knob
8. Screw

Note: The airline must also be routed at this time. It can be ran through the subframe toward the rear of the vehicle.

4. The air fitting location can be rotated by twisting the bellow assembly separate of the shock. Place the Shockwave into the coil spring pocket with the stud sticking through the OEM shock hole. See assembly **Diagram 4**. OEM Shock hole **must** be drilled out to $\frac{3}{4}$ "

1. Stud top aluminum base
2. Delrin ball lower half
3. Delrin ball upper half
4. Aluminum cap
5. 9/16" SAE Nylok jam nut
6. Threaded stud (screwed onto shock shaft)
7. Rebound adjusting knob
8. Screw

5.

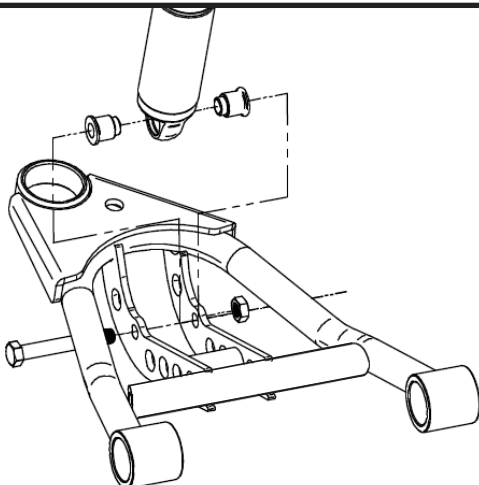

5. Raise the lower arm up to the Shockwave and bolt them together using the $\frac{1}{2}$ " x $3\frac{1}{4}$ " bolt and Nylok supplied w/ the lower arms. An aluminum spacer will be on each side of the bearing. Torque to 75 ftbs.

6. Raise the lower control arm to full compression and double-check to make sure the Shockwave does not rub on anything at anytime. Allowing the Shockwave to rub on anything will cause failure and is not a warrantable situation.

7. The best ride quality will occur around 50-60% suspension travel; depending on vehicle weight this typically occurs around 85-100 psi.



Part # 11222899 - 1964-1972 GM A-Body Front Lower StrongArms



Recommended Tools

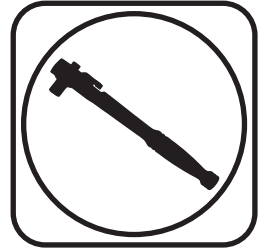

1964-1972 GM A-Body Lower StrongArms Installation Instructions

Table of contents	
Page 7.....	Lower Control Arm Components
Page 8.....	Getting Started & Installation
Page 9.....	Installing Spindles and Steering Stop



Lower Control Arm ComponentsIn the box

Item #	Part Number	Description	QTY
1	90001224	Driver Lower Control Arm (Shown)	1
1	90001225	Passenger Lower Control Arm	1
2	90000898	Lower Balljoint Assembly	2
3	70010759	Delrin Bushing - with 2" Diameter Ledge	8
4	90002062	CoilOver Bearing Spacers	4
5	90000516	1/2" ID Inner Sleeve	4
6	99501005	1/2"-13 x 3 1/2" Hex Bolt	6
7	99502009	1/2"-13 Nylok Nut	6
8	99503014	1/2" SAE Flat Washer	6
9	99371005	3/8"-16 x 1 1/4" Hex Bolt	2
10	99372012	3/8"-16 Hex Nut	2

Driver Side Shown

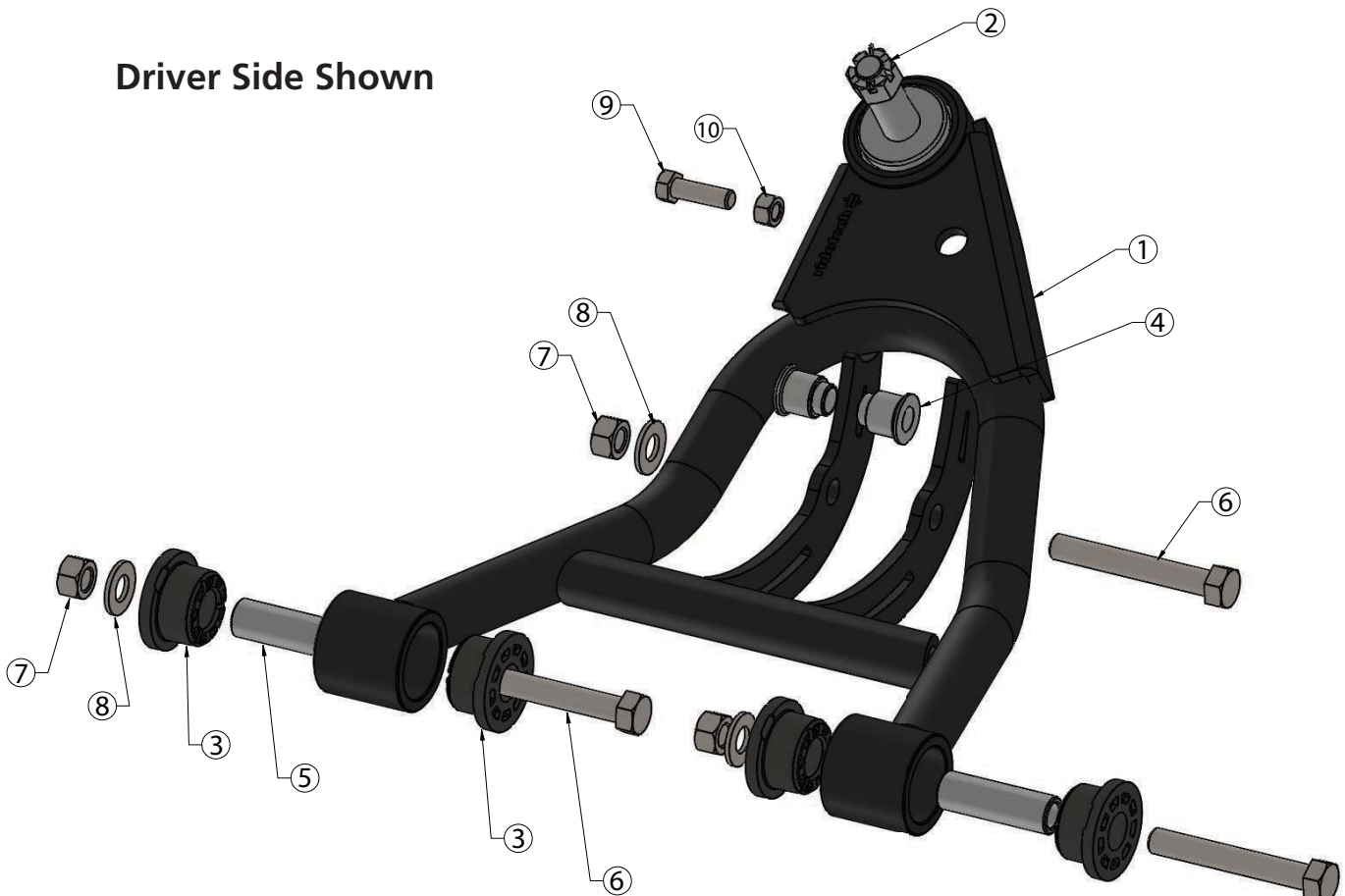



Getting Started.....

Congratulations on your purchase of the Ridetech A-Body StrongArms. These StrongArms have been designed to give your A-Body excellent handling along with a lifetime of enjoyment. Some of the key features of the TruTurn System: Balljoint angles have been optimized for the lowered ride height, Delrin bushings are used to eliminate bushing deflection along with providing free suspension movement through the entire travel. The Geometry has been optimized for excellent handling, driveability and minimal bumpsteer. The Delrin bushings are made from a material that is self lubricating so no grease zerks are needed.

Note: These control arms are designed for use with the Ridetech CoilOvers and the MuscleBar swaybar. **The factory shocks and springs or the factory sway bar will not fit these arms.**

Installation

1. Remove the entire lower control arms from the car. If you are replacing the upper control arms and spindle, remove them too. Refer to a Factory Service Manual for the proper method.
2. Drill the factory upper shock mounting hole to 3/4". This can be done easily with a Unibit.

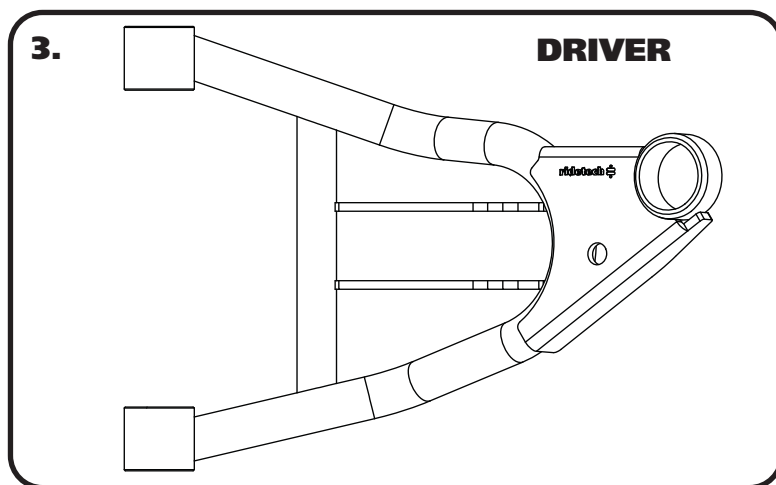

3. After removing the factory lower control arm, clean the bushing mounting surfaces on the frame. The Control Arms are marked "D" for Driver and "P" for Passenger. The Balljoint Pin points up and the Sway bar mount is on the front side of the arm. Fasten the lower arm to the frame with the hardware supplied. Note: On some cars the frame brackets may be pinched and will need to be spread back apart to allow the bushing to slide in.

Install the CoilOvers at this time. Refer to the CoilOver instructions for Assembly.

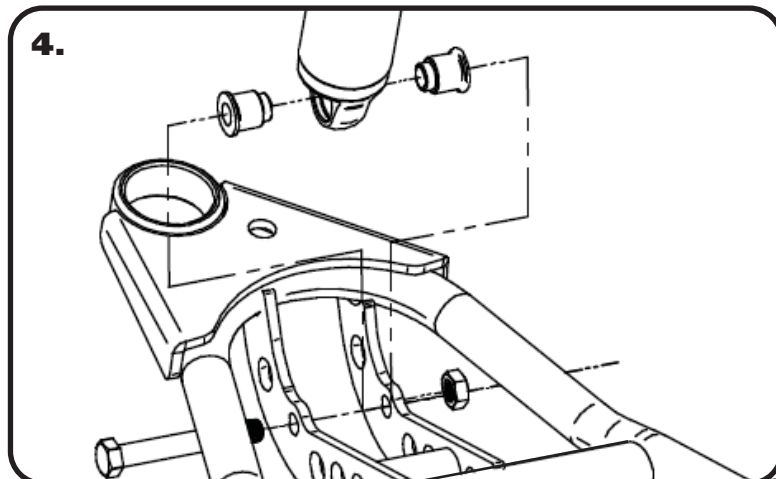

4. Insert the Bearing Spacers into the lower shock bearing. The SMALL end goes into the bearing. Swing the Control Arm up, line up the 1/2" holes with the bearing spacers, insert 1/2"-20 x 3 1/2" bolt. Install a 1/2" flat washer and nylok nut.



Installing Spindle & Setting Steering Stop

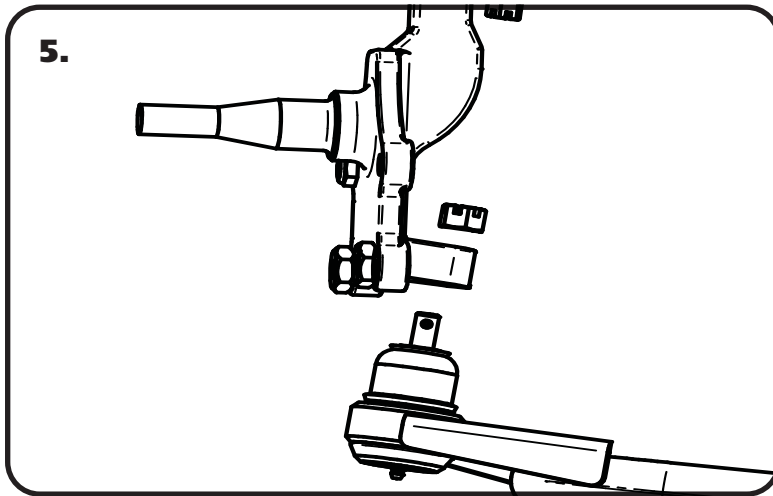

5. Attach the Spindle to the control arms.

Torque Specs:

Lower Balljoint - 65 ftlbs and tighten to line up cotter pin.

Install the Cotter Pin after tightening the ball joint nut.



6. Thread the 3/8"-16 nut onto the 3/8"-16 x 1 1/4" bolt. Thread it into the front hole of the ball joint plate. You will need to adjust the steering stop to suite your needs. This setting will vary depending on wheel and tire size and other suspension components.

7. Tighten all fasteners. If you are going to install the Ridetech MuscleBar, now is a good time to do it.

Suggested Alignment Specs:

Camber: Street: -.5 degrees
Caster: Street: +3.0 to + 5.0 degrees
Toe: Street: 1/16" to 1/8" toe in



Part # 11223699 - 1964-1972 GM A-Body Front Upper StrongArms



Recommended Tools



1964-1972 GM A-Body Upper StrongArms Installation Instructions

Table of contents

- Page 11..... Upper Control Arm Components
- Page 12..... Getting Started
- Page 13..... Caster Explained
- Page 14..... Offset Upper Control Arm Crossshaft
- Page 15..... Installing Spindle and Alignment



Upper Control Arm ComponentsIn the box

Item #	Part Number	Description	QTY
1	90001222	Driver Upper Control Arm (Shown)	1
1	90001223	Passenger Upper Control Arm	1
2	90000908 kit	Upper Ball Joint Kit	2
3	90000914 kit	Caster Slug Crossshaft Kit	2
4	70010883	Caster Slug	4
5	70010759	Outer Delrin Bushing with 2" Lip	4
6	70010827	Inner Delrin Bushing with 1.75" Lip	2
7	70010826	Inner Delrin Bushing with No Lip	2
8	90002737	Aluminum T-Washer	4
9	99253008	1/4" SAE Flat Washer	8
10	99622005	5/8" -18 Jam Lock Nut - Included with 90000914 kit	4
11	99433004	7/16" USS Flat Washer - NOT SHOWN	4

Driver Side Shown

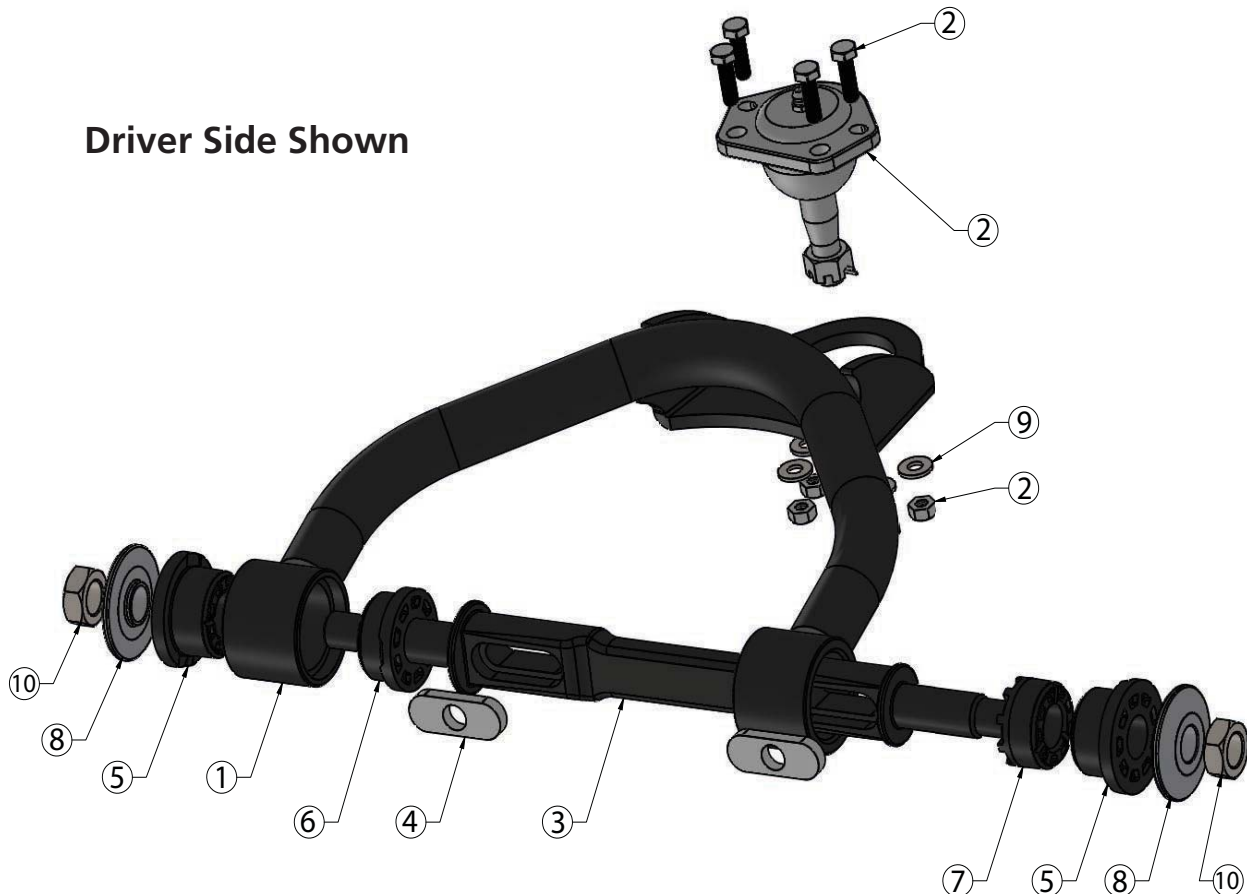



Getting Started.....

Congratulations on your purchase of the Ridetech A-Body StrongArms. These StrongArms have been designed to give your A-Body excellent handling along with a lifetime of enjoyment. Some of the key features of the TruTurn System: Balljoint angles have been optimized for the lowered ride height, Delrin bushings are used to eliminate bushing deflection along with providing free suspension movement through the entire travel. The Geometry has been optimized for excellent handling, driveability and minimal bumpsteer. The Delrin bushings are made from a material that is self lubricating so no grease zerks are needed.

When assembling the Control Arms tighten the cross shaft nuts enough to create drag on the delrin bushings, the arm should still move through its travel by hand.

Installation

1. Remove the entire upper control arms from the car. If you are replacing the lower control arms and spindle, remove them too. Refer to a Factory Service Manual for the proper method.

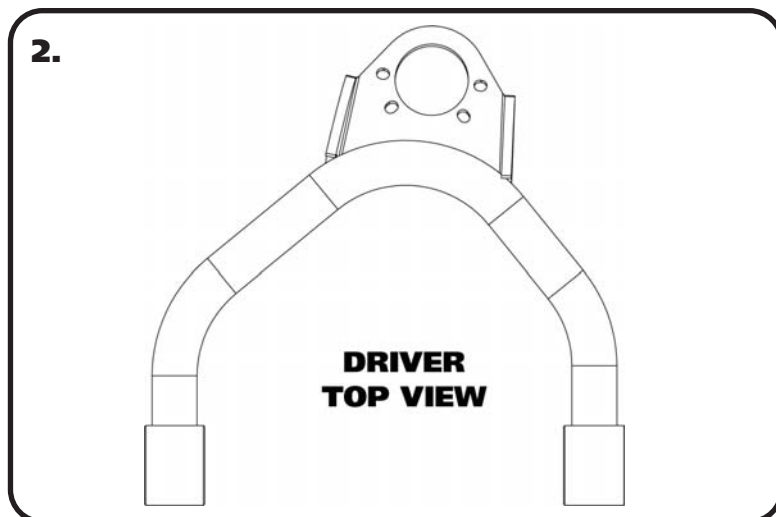

2. The Upper Control Arm is attaching the factory mount using factory hardware. The driver side arm is shown in **Figure "2"**. The Balljoint located on the arm to the front of the car. Install the Ball Joints in the control arms using the illustration on the previous page as a reference. Torque the hardware to 10 ftlbs.



3. The Upper Control Arm is attaching the factory mount using factory hardware with the supplied 7/16" Flat Washer under the OEM Nut. The driver side arm is shown in **Figure "2"**. The Arrow on the Cross shaft points to the front of the car. Page 4 & 5 has information about Caster and the Caster Slugs.



Caster Explained

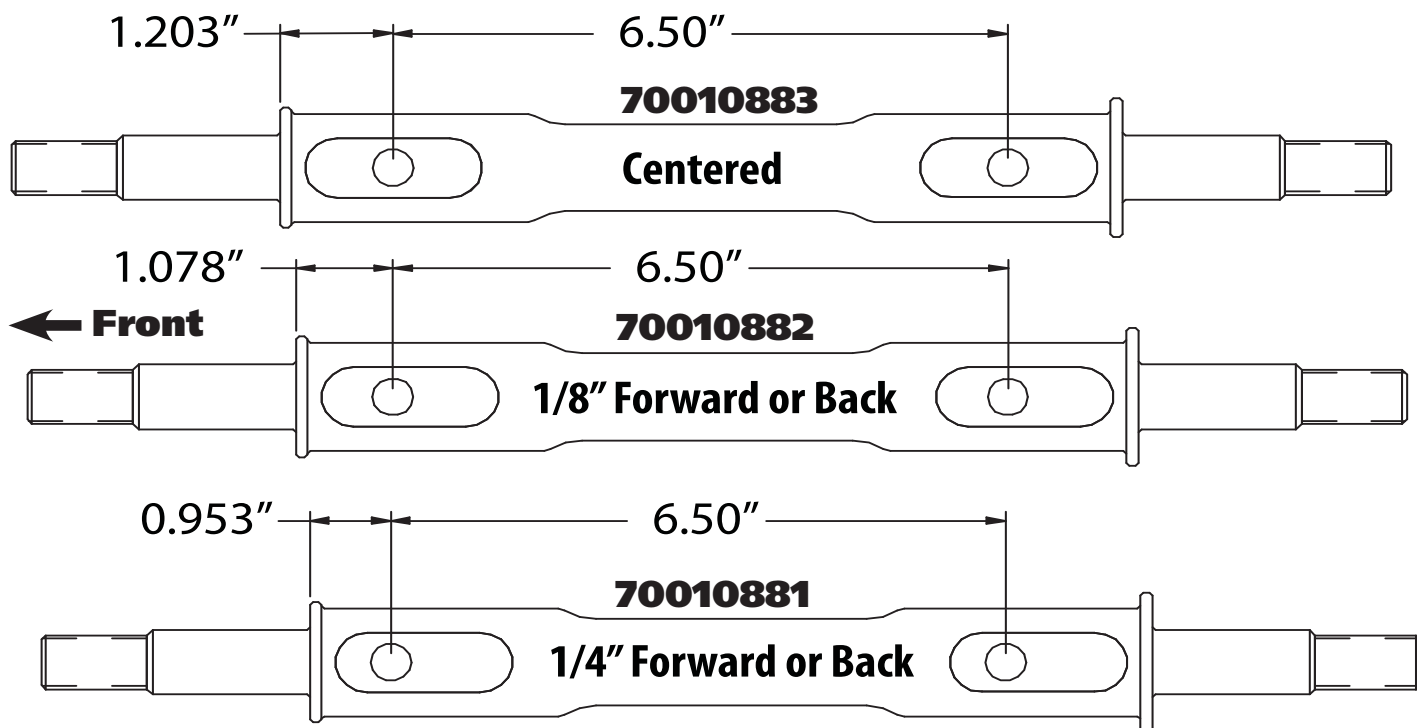

These StrongArms come equipped with a changeable caster slug setup. This allows you to add or remove caster from the front suspension, if desired. The caster slugs that come supplied in the kit are setup to be centered. The caster slugs allow you to add or remove caster without having to use a stack of shims. If more or less caster is desired, optional slugs can be purchased from Ridetech or your Ridetech dealer.

1/8" = 70010882

1/4" = 70010881

Caster Explained:

To understand caster you need to picture an imaginary line that runs through the upper balljoint and extends through the lower balljoint. From the side view the imaginary line will tilt forward or backward. The tilting of this imaginary line is defined as caster.

Caster is measured in degrees by using a caster gauge. If the imaginary line described above tilts towards the back of the vehicle at the top, then you have positive caster. If the imaginary line tilts forward then you have negative caster.

Positive caster provides the directional stability in your vehicle. Too much positive caster will make the steering effort difficult. Power steering will allow you to run more positive caster. Negative caster requires less steering effort but will cause the vehicle to wander down the highway.



Offset Upper Control Arm Shaft

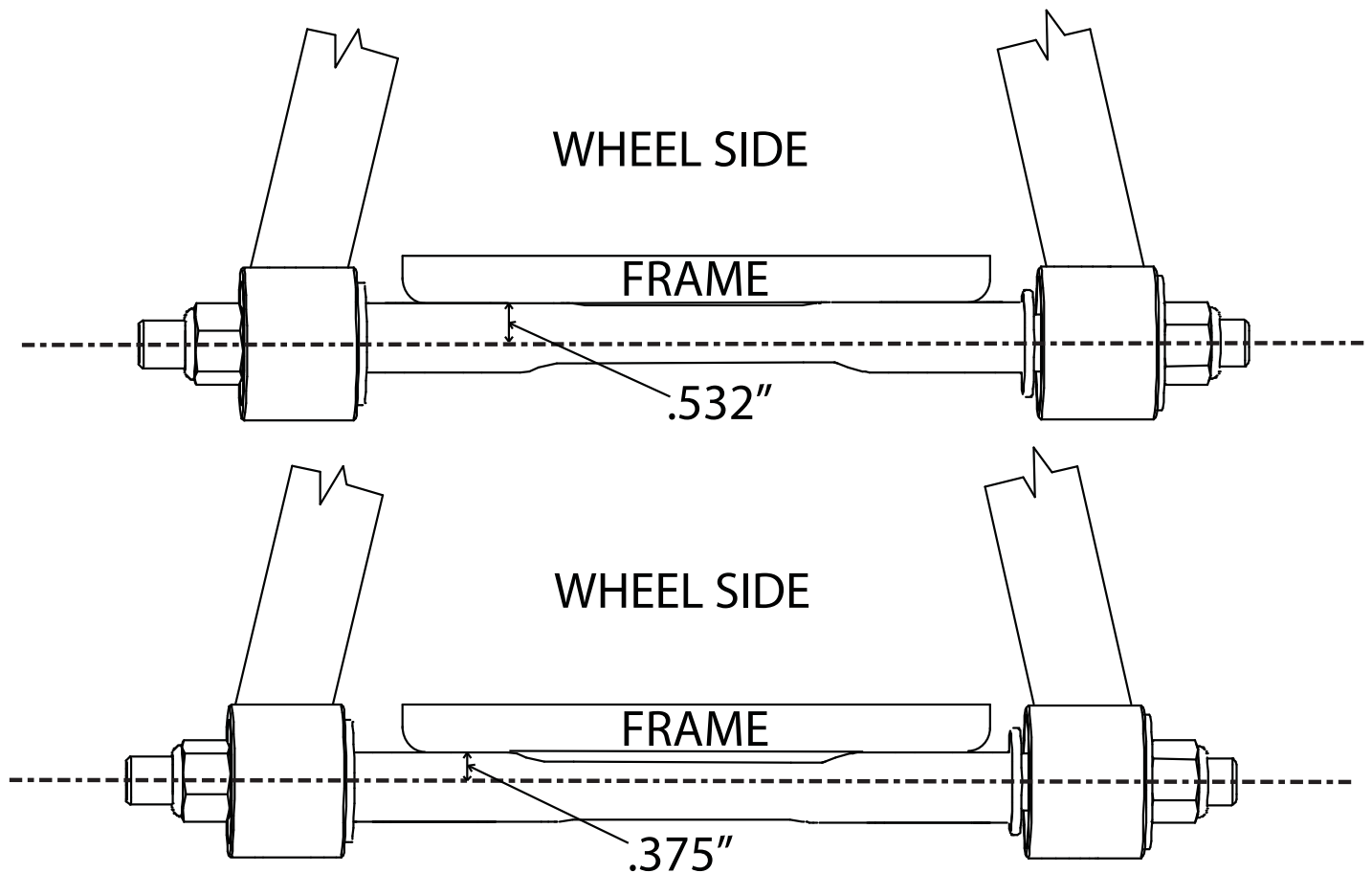

The cross shaft that is used in the upper control arms is offset. The offset combined with the caster slug option allows you to achieve the alignment setting you desire with minimal shims. To change the direction the Icon faces simply spin the cross shaft in the control arm.

If you are after a **Street Alignment** bolt the upper control arm to the frame mount with the arm offset to the outside of the car. The Ridetech Icon and Caster Slugs will be facing the wheel.

If a more aggressive **Track or Autocross** alignment is desired, bolt the control arm to the frame bracket with the arm offset to the inside of the car. The Ridetech Icon and Caster Slugs will be facing the engine.



Installing Spindle and Alignment

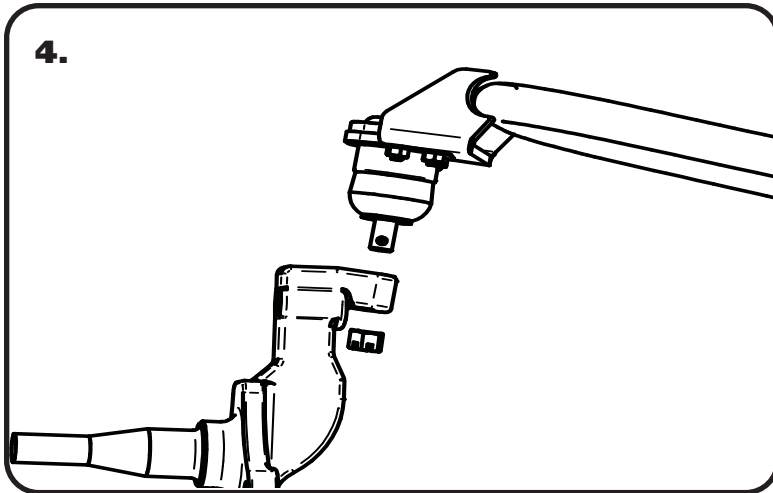

4. Attach the Spindle to the control arms.

Torque Specs:

Upper Balljoint - 50 ftlbs and tighten to line up cotter pin.

Install the Cotter Pin after tightening the ball joint nut.

5. Tighten all fasteners.

When assembling the Control Arms tighten the cross shaft nuts enough to create drag on the delrin bushings, the arm should still move through its travel by hand.

Suggested Alignment Specs:

Camber:	Street: -.5 degrees
Caster:	Street: +3.0 to + 5.0 degrees
Toe:	Street: 1/16" to 1/8" toe in



Part # 11009310 - A/F/X Tall Spindle Kit



Recommended Tools

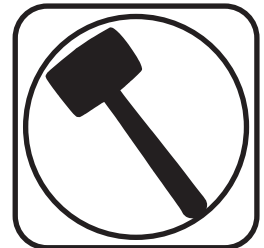
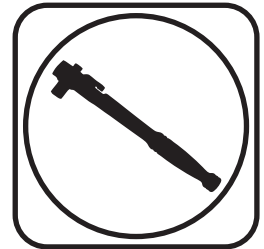

A/F/X Tall Spindle Kit

Installation Instructions

Table of contents

- Page 17..... Included Components and Hardware
- Page 18..... Getting Started and Installation
- Page 19..... The Finish

THIS SPINDLE IS DESIGNED TO FIT 64-72 GM A-BODY, 67-69 GM F-BODY, AND 68-74 GM X-BODY. THESE SPINDLES ARE SYMMETRICAL, THEY AREN'T SIDE SPECIFIC UNTIL THE STEERING ARM IS BOLTED ON.

THESE SPINDLES ARE A DIRECT REPLACEMENT FOR OEM DISC BRAKE SPINDLES. IF YOUR CAR HAS DRUM BRAKES, YOU WILL HAVE TO CONVERT IT TO DISC BRAKES. THEY WILL ACCEPT ANY BRAKE KIT THAT IS DESIGNED FOR THE OEM DISC BRAKES SPINDLES.





Major ComponentsIn the box

Item #	Part #	Description	QTY	
1	11009307	Spindles (Pair)	1 pair	
2	90002743	3/4"-20 Spindle Nut Kit	1 kit	
Item #	Part #	Description	Usage	QTY
Hardware				
3	99501009	1/2"-20 x 1 3/4" Hex Bolt	Steering Arm to Spindle	2
4	99502005	1/2"-20 x 2" Hex Bolt	Steering Arm to Spindle	2
5	99503015	1/2" Split Lock Washer	Steering Arm to Spindle	4
6	99503014	1/2" SAE Flat Washer	Steering Arm to Spindle	4

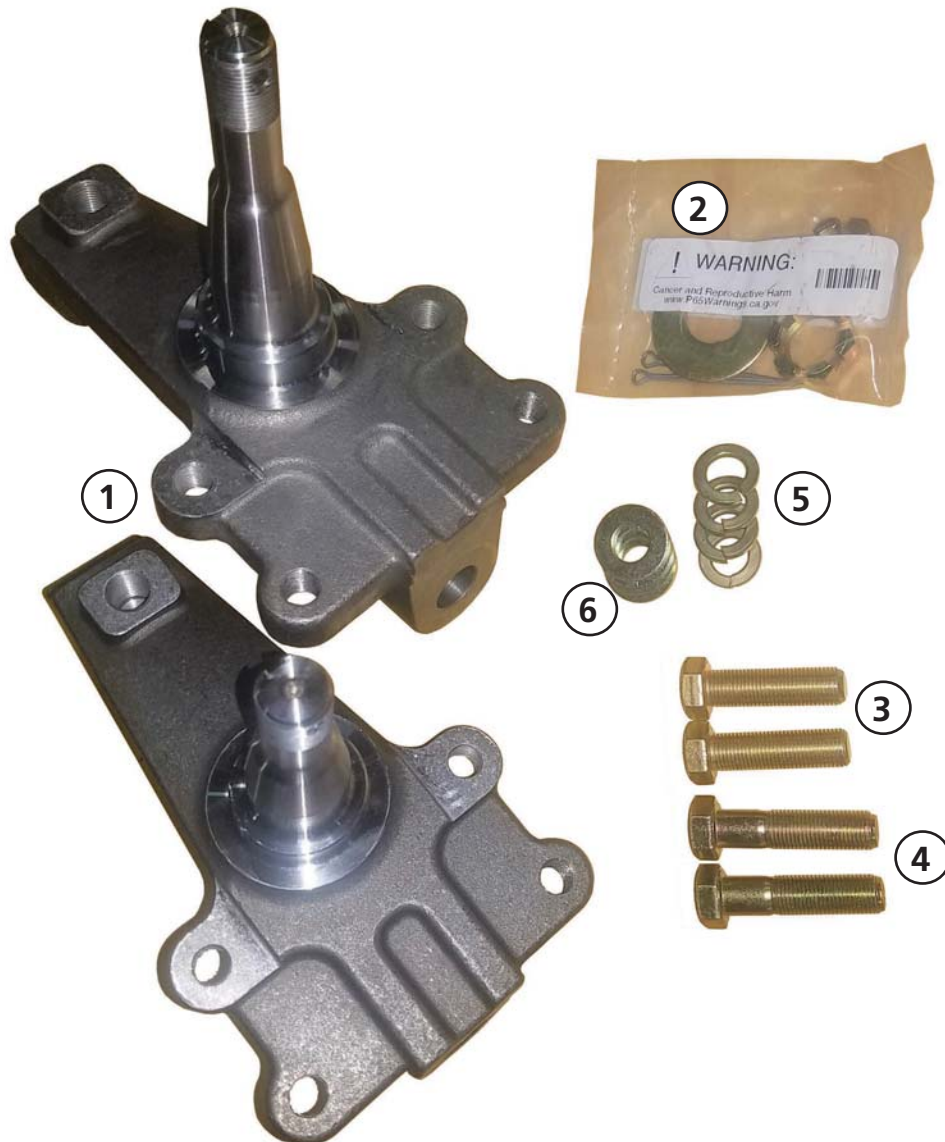



Getting Started.....

These spindles will fit '67-69 Camaro, '64-'72 Chevelle, and '68-'74 Nova. They will provide a 2" drop, and are taller than stock to improve the car's cornering ability. The raised upper ball joint induces negative camber gain and positive caster gain. This helps keep the tires flat on the pavement when cornering. This camber action change also raises the roll center for less body roll, and transfer the car's center of gravity inboard in the turn as well. You will see an appreciable improvement in handling.

These spindles are designed around stock disc brake spindles and will accept any disc brake set up designed for those. **The only modification we discovered to be necessary was a small trim on the bottom of the stamped 1/4" steel caliper bracket that holds the caliper.** It is an area that is not stressed and will not cause any loss of strength. Trim only enough to make the caliper bracket clear the spindle. If you are using the factory dust shields, they will also require trimming. If your car came with drum brakes, be sure to swap to the appropriate disc brake master cylinder and valving.

Installation



IF YOU HAVEN'T ALREADY DONE SO, REMOVE THE OEM SPINDLE. IF REUSING THE EXISTING CALIPERS, BE SURE TO SUPPORT THEM TO KEEP FROM PUTTING UNWANTED STRESS ON THE BRAKE LINES.

1 & 2. Remove the OEM steering arms from the spindles that were removed from the car. The steering arm will bolt to the **BOTTOM** set of holes in the spindle using the supplied 1/2" hardware. The mounting bosses of the steering arm are 2 different thicknesses. The thicker boss uses a 1/2"-20 x 2" hex bolt. The thin boss will use a 1/2"-20 x 1 3/4" bolt. Install a 1/2" split lock washer followed by a 1/2" SAE flat washer on each bolt. **We suggest using RED Threadlocker on the steering arm mounting hardware.** Line up the steering arm mounting holes with the bottom 2 holes of the spindle. Insert the 2" long bolt through the thick boss and the 1 3/4" long bolt through the thin boss, threading the bolts into the spindle. Torque the steering arm hardware to 100 ftlbs.



NOTE: Some steering arms have 7/16" mounting holes, they will need to be drilled out using a 1/2" drill bit.



The Finish

3. Attach the spindles to the control arms. Torque the ball joints and tie rods end using the torque specs below.

Torque Specs:

Lower Ball Joint -	65 ftlbs and tighten to line up cotter pin.
Upper Ball Joint -	50 ftlbs and tighten to line up cotter pin.
Tie Rod End -	35 ftlbs and tighten to line up cotter pin.

Wheel Bearing Tightening:

While turning the rotor, tighten the nut to 12 ftlbs with a torque wrench. Back off the nut one flat and insert the cotter pin. If the slot and pin hole don't line up, back off the nut an additional half flat or less as required to insert the pin. Note: Bearings should have zero preload and .001" to .008" of end movement. Bend the ends of the cotter pin, replace the dust cap. On a disc brake with the caliper removed, it's normal to have a slight amount of play detectable in the bearing.

5. Recheck all hardware before driving.

6. PUMP THE BRAKE PEDAL BEFORE DRIVING TO RESET THE BRAKE PADS TO THE ROTOR. IF YOU HAD THE CALIPERS REMOVED, BLEED THE BRAKE SYSTEM.

Suggested Alignment Specs:

Camber:	Street: -.5 degrees
Caster:	Street: +3.0 to + 5.0 degrees
Toe:	Street: 1/16" to 1/8" toe in



Part # 11239120 - 1964-1967 GM A-Body Front SwayBar

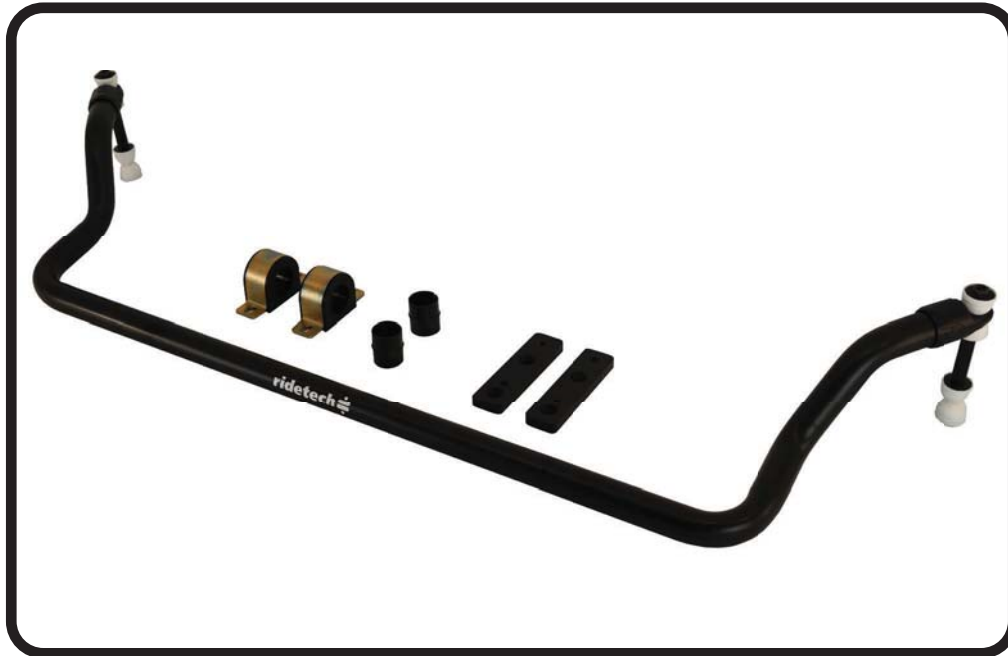

Recommended Tools

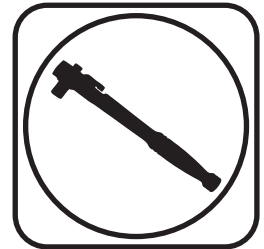

1966-1967 GM A-Body Front SwayBar Installation Instructions

Table of contents

- Page 21..... Included Components and Hardware List
- Page 22..... SwayBar Installation

Hardware Torque Specifications

- 5/16"-16..... 17 ftlbs
- 3/8"-16..... 30 ftlbs

www.ridetech.com 

REV1 5/28/20

Major ComponentsIn the box

Part #	Description	QTY
90001230	Front SwayBar	1
90002932	End Link Kit	1
70012394	Delrin Sway Bar Bushing Liner	2
90002513	Bushing Strap	2
90001099	SwayBar Bushing	2
90001254	Bushing Mount Adapter	2

HARDWARE KIT99010083

QTY	Part Number	Description
ADAPTER PLATE		
2	99371032	3/8"-16 x 1 1/4" Flat Head
2	99311025	5/16"-18 x 1 1/4" Flat Head
2	99371005	3/8"-16 x 1 1/4" Hex Bolt
2	99311011	5/16"-18 x 1 1/4" Hex Bolt
2	99373002	3/8" Flat Washer
2	99313001	5/16" SAE Flat Washer
2	99373006	3/8" Split Lock Washer
2	99313003	5/16" Split Lock Washer
1	90002263	Red Loctite

QTY	Part Number	Description
BUSHING STRAP		
4	99371065	3/8"-16 x 3/4" Hex Bolt
4	99373002	3/8" Flat Washer
4	99373006	3/8" Split Lock Washer

Getting Started.....

This SwayBar Kit utilizes a Delrin Liner in the SwayBar Bushing. The Delrin Liner allows the SwayBar to move freely and quietly in the Bushing. The Delrin is self-lubricating, no lubrication is required.

Note: The threaded holes in the frame can be either 5/16"-18 or 3/8"-16. Hardware is supplied for both.

1. Jack the vehicle up to a safe working height and support with jack stands. Make sure the jack stands are stable before working under the car.
2. Remove the stock sway bar.
3. After removing the stock sway bar, determine what size hardware the frame will require.



4. Open the Delrin Liner at the split and slip it over the SwayBar. Position it in the area that the bushing will ride based on the location of the stock swaybar. Do this on both ends of the swaybar.



5. Open the SwayBar Bushing at the split and slide it **OVER** the Delrin Liner. Do this on both Delrin Liners.



6.

6. Slip the Bushing Straps over the SwayBar Bushings. **Before continuing to the next step, determine the bolt size required for your installation. The threaded holes in the frame can be either 5/16"-18 or 3/8"-16. Hardware is supplied for both.**

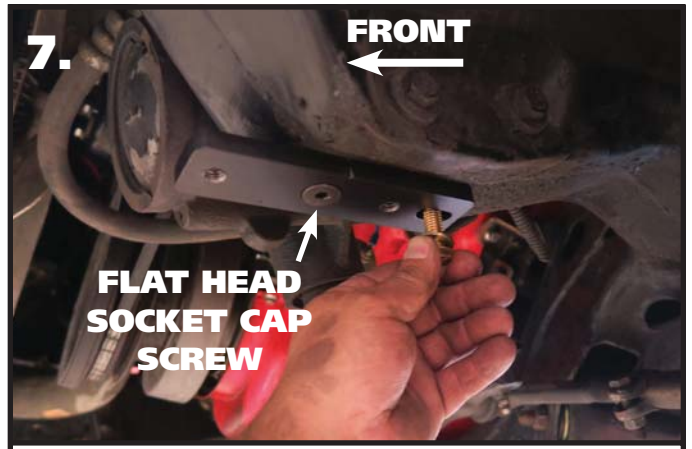

7.

**FLAT HEAD
SOCKET CAP
SCREW**

7. Hold the Frame Plate up to the OEM holes, the Counter Sunk hole will be positioned over the front hole with the slot to the rear. Apply Red Loctite to the Flat Head Bolt. The rear 1 1/4" long bolt uses a Split Washer and Flat Washer. Torque Hardware.



8.

8. Slide the SwayBar into position on the car with the SwayBar arms above the tie rods. Install a 3/8" Lock Washer & 3/8" Flat Washer on the 3/8"x 3/4" Hex Bolts. Do **NOT** Complete tighten the Hardware, it will be left partially loose until the End Links are installed.

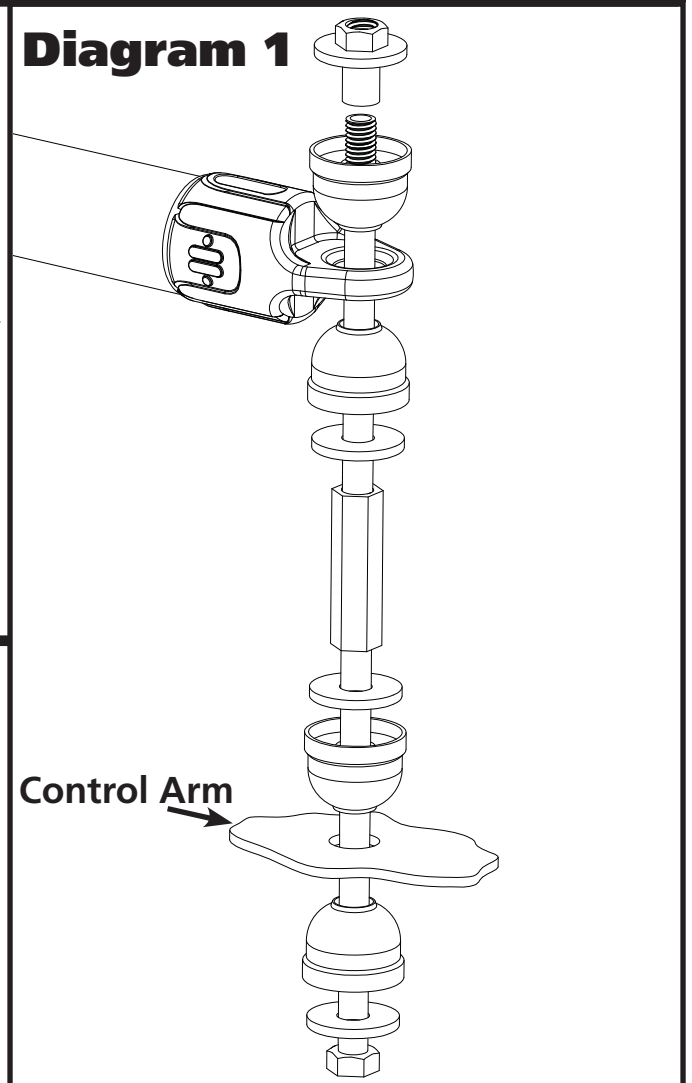

Diagram 1

Control Arm



9

9. Install the End Links using **Diagram 1** as a reference. Install both end links before tightening the end link hardware. Tighten the end link barrel nut until it is flush with the end of the bolt, and then tighten it 2 more complete rounds.

10. Torque the SwayBar mounting hardware to 30 ftlbs.



Part # 11236699 - 1964-1967 GM "A"Body Rear Upper StrongArm Kit



Recommended Tools



1964-1967 GM "A"Body Rear Upper StrongArms Installation Instructions

Table of contents

- Page 24..... Included Components
- Page 25..... StrongArm Installation





Included ComponentsIn the box

Part Number	Description	QTY
90001116	Upper Control Arms (Set to 12.750")	2
90001318	RH R-Joint Threaded Housing Assembly (Installed in bars)	2
99752004	3/4" -16 Jam Nut (Installed on R-Joint End	2
70013784	R-Joint Spacers	4
R-Joint Components - (Installed in R-Joint ends)		
70013275	R-Joint Center Ball	2
70013276	R-Joint Composite Center Ball Cage	2
70013279	Retaining Ring	2
70013280	Wavo Wave Spring	2

Hardware Kit# - 99010096

99501005	1/2" -13 x 3 1/2" Hex Bolt	Upper StrongArm	4
99502009	1/2" -13 Nylok Nut	Upper StrongArm	4
99503014	1/2" SAE Flat Washer	Upper StrongArm	4

R-JOINT SPACER INSTALLATION

Install the Spacers by inserting the SMALL side of the SPACER into the Center Pivot Ball. Push them in until they bottom out and stop.

UPPER R-JOINTS

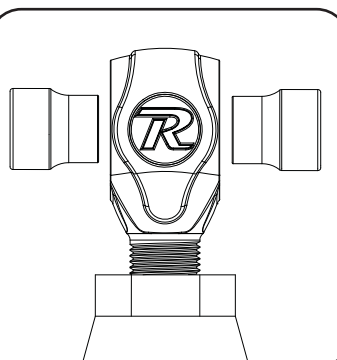

New R-Joints will be quite stiff (75-90 in/lbs breakaway torque) until they "break in" after a few miles of use. After the break in period they will move much more freely. Because the composite bearing race contains self lubricating ingredients, no additional lubrication is needed or desired. Any additional lubrication will only serve to attract more dirt and debris to the R-Joint and actually shorten its life.

STRONGARM ORIENTATION

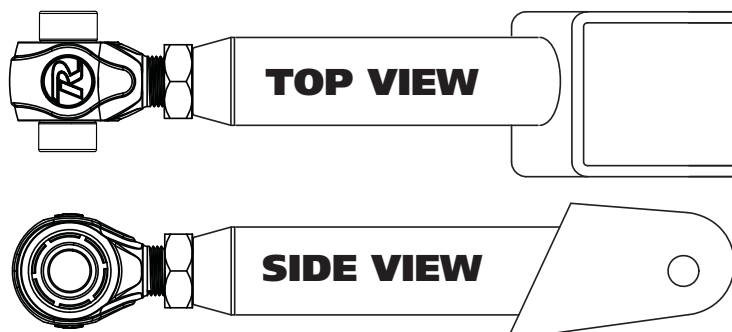

THIS ILLUSTRATION SHOWS HOW THE UPPER STRONGARM IS TO BE INSTALLED IN YOUR A-BODY. BOTH UPPER STRONGARMS ARE OFFSET TO SAME SIDE. THIS DESIGN IS BASED OFF THE OEM CONTROL ARMS TO KEEP THE DIFFERENTIAL CENTERED.



StrongArm Installation

1.

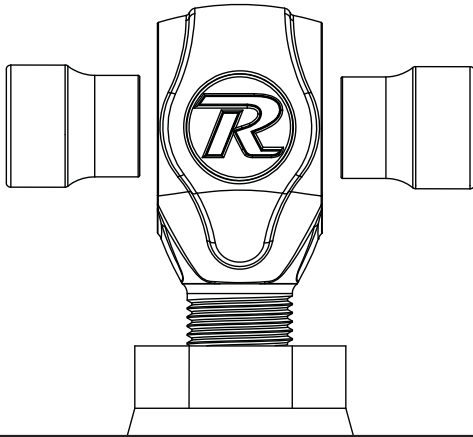

1. Remove the OEM upper control arm. Inspect the condition of the bushings in the axle housing. If you are also installing the Axle Housing R-Joints, install them before installing the new upper StrongArms. Check the length of the upper StrongArm, it should be set at 12.750". Ensure that the jam nut is tight. Insert the R-Joint Spacers into the R-Joint by installing the small end of the spacers into the R-Joint. Push them in until they bottom out and stop.

2.



2. Insert the R-Joint end of the upper StrongArm into the OEM location, making sure the StrongArm is positioned correctly. Use the illustration on **Page 24** to help determine the correct orientation. Line up the through hole of the R-joint with the upper control arm mounting holes. Insert a 1/2"-13 x 3 1/2" hex bolt through the holes. Install a 1/2" flat washer and 1/2"-13 nylok nut on the threads of the bolt sticking through the frame. Torque to 75 ftlbs.

3.



3. Slip the end of the upper Strongarm over the axle housing bushing. Line up the holes of the StrongArm with the through hole of the bushing. Insert a 1/2"-13 x 3 1/2" hex bolt through the holes. Install a 1/2" flat washer and 1/2"-13 nylok nut on the threads of the bolt sticking through the frame. Torque the hardware to 75 ftlbs.



Part # 11224499 - 1964-1972 GM "A"-Body Rear Lower StrongArm Kit

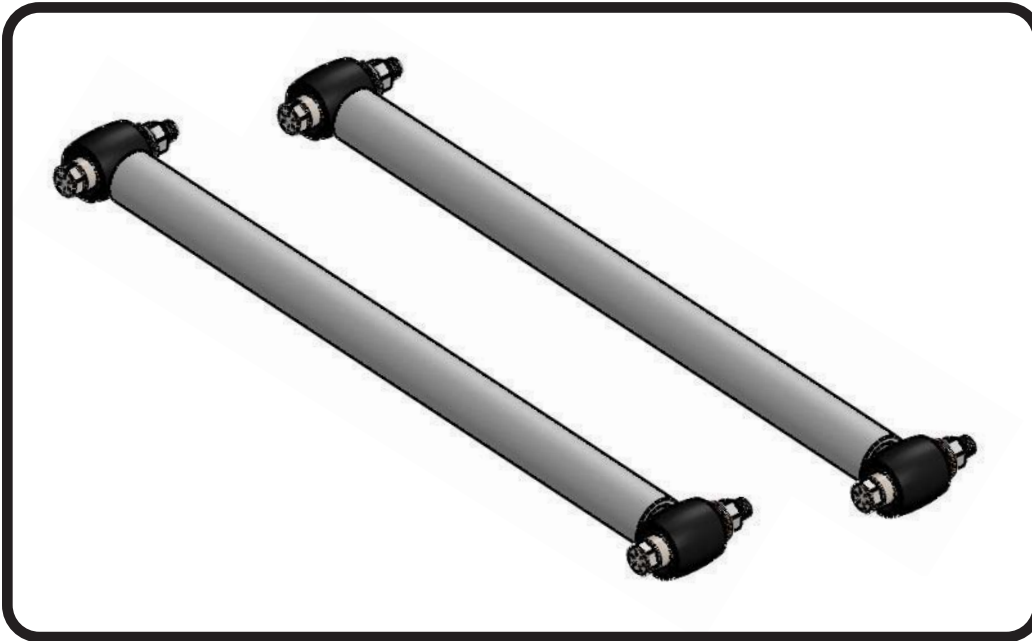

Recommended Tools

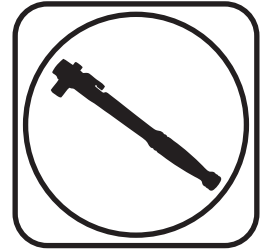

1964-1972 GM "A"-Body Rear Lower StrongArms Installation Instructions

Table of contents

Page 27..... Included Components & Hardware
Page 28..... Installation





Included ComponentsIn the box

Item #	Part Number	Description	QTY
1	90002826	Lower Control Arms	2
2	70013784	1/2" ID R-Joint Spacer	8
R-Joint Components - (Installed in bar ends)			
	70013275	R-Joint Center Ball	4
	70013276	R-Joint Composite Center Ball Cage	4
	70013279	Retaining Ring	4
	70013280	Wavo Wave Spring	4
Hardware Kit #99010096			
3	99501005	1/2" -13 x 3 1/2" Hex Bolt	4
4	99502009	1/2" -13 Nylok Nut	4
5	99503014	1/2" SAE flat Washer	4

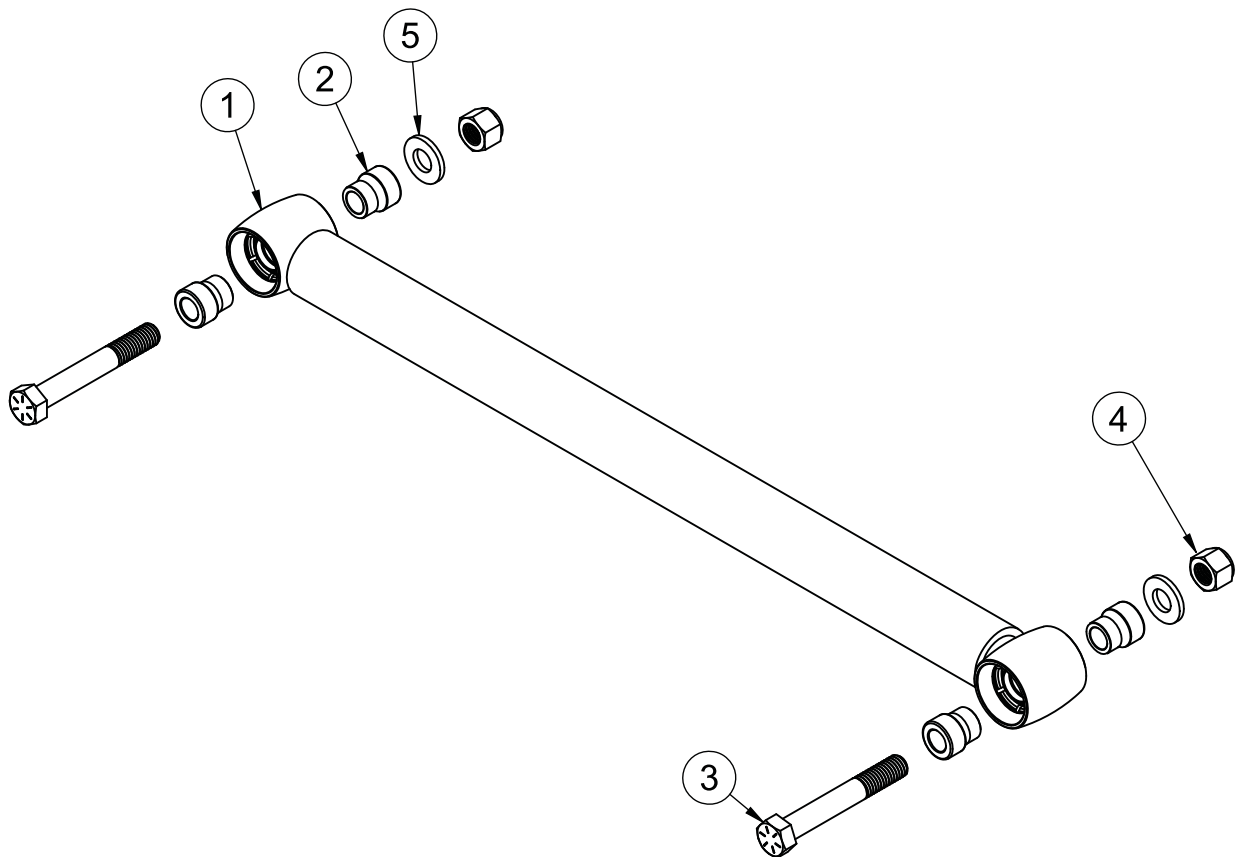



StrongArm Installation

R-JOINT SPACER INSTALLATION

Install the Spacers by inserting the SMALL side of the SPACER into the Center Pivot Ball. Push them in until they bottom out and stop.

UPPER R-JOINTS

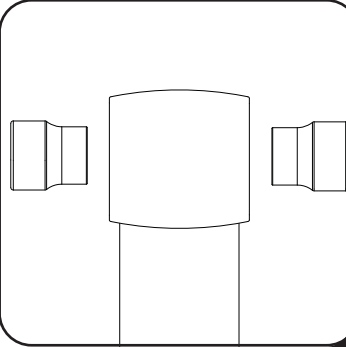

New R-Joints will be quite stiff (75-90 in/lbs breakaway torque) until they "break in" after a few miles of use. After the break in period they will move much more freely. Because the composite bearing race contains self lubricating ingredients, no additional lubrication is needed or desired. Any additional lubrication will only serve to attract more dirt and debris to the R-Joint and actually shorten its life.

1. Remove the factory lower trailing arm. Do one side at a time to keep the axle from rotating.



2. Insert the Spacers into the R-Joints. Refer to the above diagram.

3. Attach to front on the lower StrongArm to the frame using the 1/2" x 3 1/2" bolts and Nylok nuts supplied.



4. Attach to rear of the lower StrongArm to the frame using the 1/2" x 3 1/2" bolts and Nylok nuts supplied.

Note: Tighten the hardware to 75 ft-lbs.



Major ComponentsIn the box

Part #	Description	QTY
R-Joint Housing Components		
90002122	R-Joint Bushing Housing with R-Joint Components installed	2
70013784	R-Joint Spacers	4
R-Joint Components Installed In Housing		
70013275	R-Joint Center Ball	
70013276	R-Joint Composite Center Ball Cage	
70013279	Retaining Ring	
70013280	Wavo Wave Spring	
Bushing Removal & Installation Tool Components		
90002912	1.875" ID x 1.00" Long Notched Sleeve	1
90002880	1.825" OD Washer	1
90002913	2.625" OD Washer with Flat	1
90002559	2.375" ID x 2.375" Long Sleeve	1
99505003	1/2"-10 x 8" ACME Threaded Rod	1
99502013	1/2"-10 ACME Hex Nut	2
99503003	1/2" Flat Washer	2

Getting Started.....

This kit is designed to aid in the removal of the OEM bushings and installation of the Delrin R-Joint Axle Housing Bushing. This guide will show you how the kit is to be used. It is important to not get the bushings crooked on installation.

2.

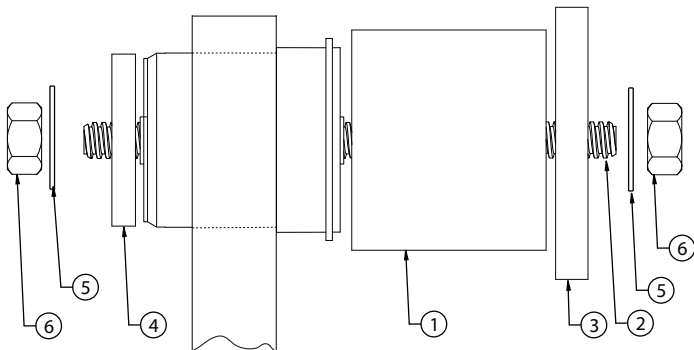

1. Start by sticking the 2 3/8" Sleeve(1) over the OEM bushing. Insert the 1/2"-10 x 8" Threaded Rod(2) into the OEM bushing. Install the Large 2 5/8" Diameter Flat Sided Washer(3) onto the threaded rod on the Sleeve side. Install the Small 1.825" Washer(4) on the threaded rod (on the side with the bushing sticking through the housing). Install a 1/2" washer(5) and nut(6) on each end of the threaded rod. Use **Images 1 & 2** as a reference.



Bushing Housing Installation

2.

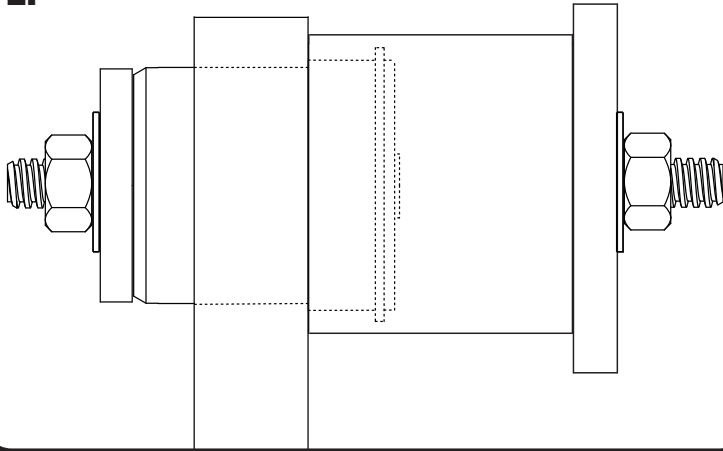

2. Tighten the 1/2" nuts, pushing the bushing out of the mount.

3.

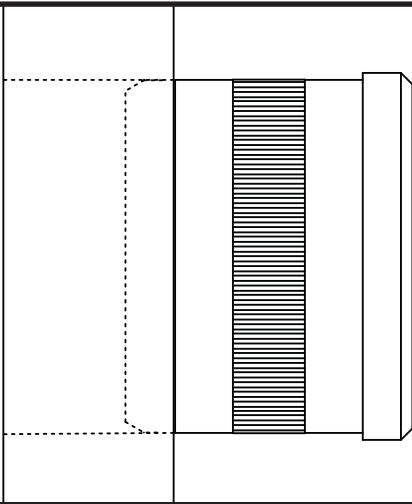

3. Start the R-Joint Housing into the OEM bushing hole by hand.

4.

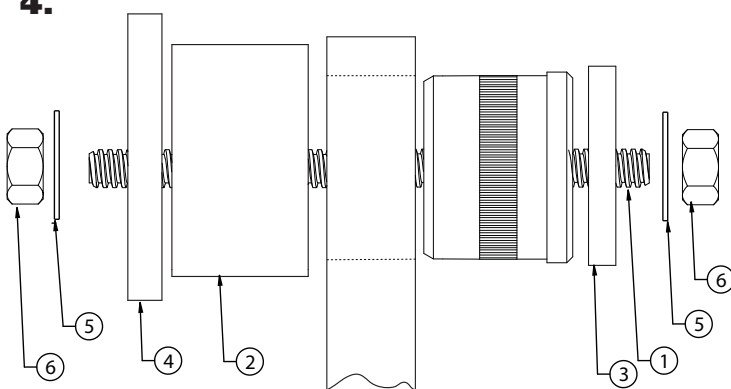

4. Insert the 1/2"-10 x 8" Threaded Rod(1) into the bushing. Install the 1 7/8" ID x 1" Long Sleeve(2) on the opposite side of the bushing. This sleeve will be centered over the bushing hole. Install the 1.825" Washer(3) on the stud (on the bushing side). Install the 2 5/8" Flat Sided Washer(4) on the 1 7/8" Sleeve side. Install a 1/2" washer(5) and nut(6) on each end of the threaded rod. Use **Images 4-7** as a reference. **12 BOLT DIFFERENTIALS REQUIRE A SPECIFIC ORIENTATION OF THE 1" LONG SLEEVE AND THE FLAT SIDED 2 5/8" WASHER. IMAGES 5 & 6 ILLUSTRATE THE ORIENTATION.**



Bushing Housing Installation

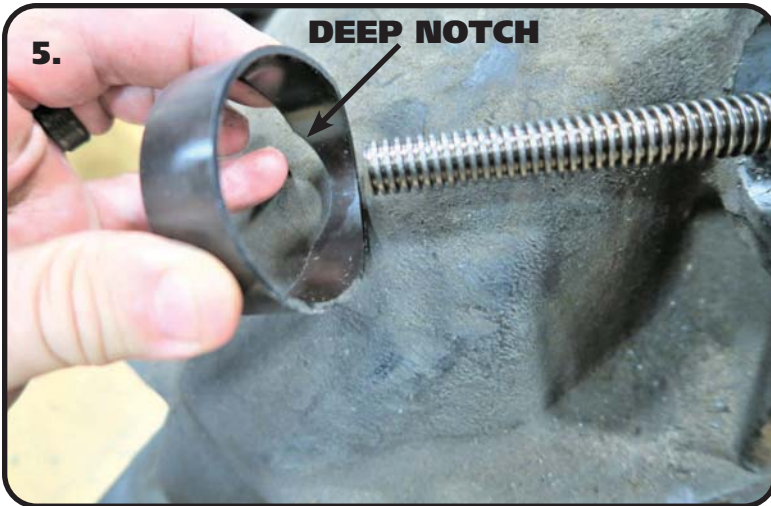

5. 12 BOLT ONLY When installing the R-joint in a 12 bolt, the orientation of some components of the installation tool is important. **Image 5** is of the 1 7/8" ID x 1" Long Sleeve. The sleeve has a notch cut in each side of it. One side has a wide, shallow notch. The other side has a narrow, deep notch. A 12 bolt requires the wide, shallow notch to be up against the bushing ear of the axle. The narrow, deep notch is for clearance of the axle housing. The deep notch will need to be positioned so that the housing isn't pushing against the sleeve, causing it to not sit flat against the ear of the axle.



6. 12 BOLT ONLY The 2 5/8" Flat Sided Washer is made with a FLAT in it to clear the axle housing while installing the r-joint housing. You will need to position the Flat Sided Washer so it isn't hitting against the axle housing.

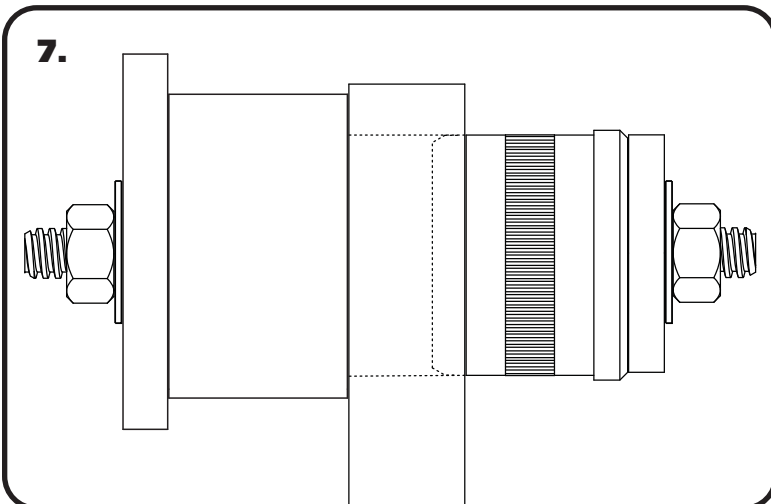

7. Snug down the nuts enough to hold the sleeve and washers in place. Check to make sure the sleeve is centered over the hole and the 1.825" washer is center on the bushing housing. If installing in a 12 Bolt Housing, refer to **Steps 5 & 6** for proper orientation of the installation tool. Tighten the nuts to press the bushing housing into the axle housing. Tighten the nuts until the housing bottoms in the axle mount.



Bushing Housing Installation

6.

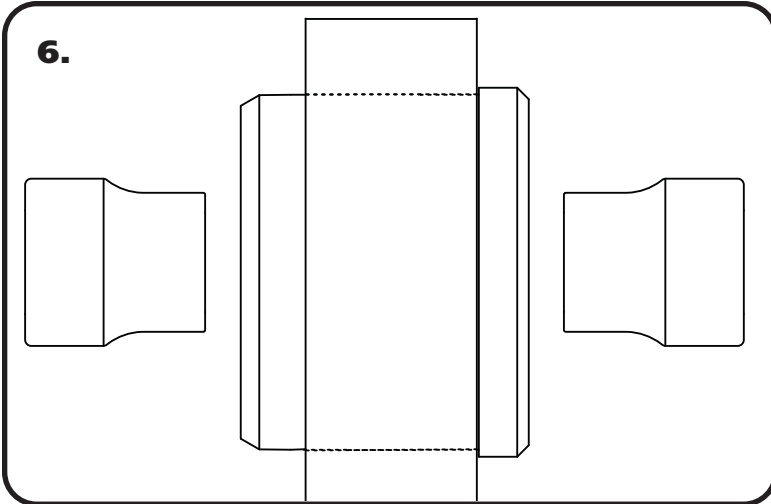

8. Install the Spacers by inserting the SMALL side of the SPACER into the Center Pivot Ball. Push them in until they bottom out and stop.

9. Install your Ridetech StrongArms. Refer to the instructions supplied with the StrongArms.



Part # 11225401 - 1964-1972 GM A-Body Rear Shockwave

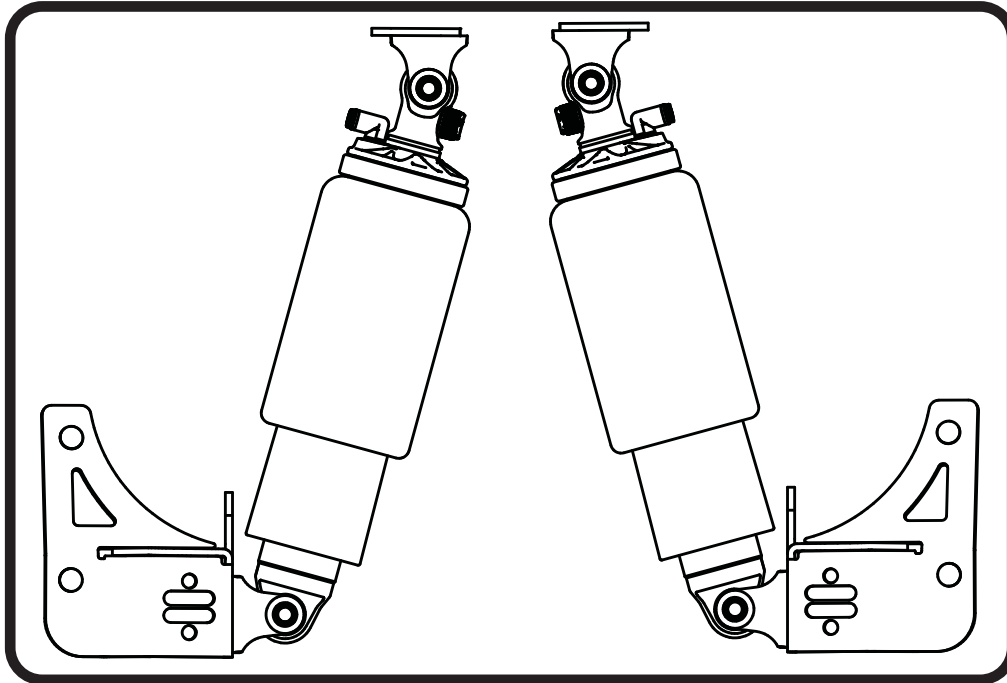

Recommended Tools

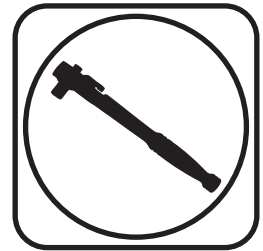

64-72 A-Body HQ Series Rear Shockwave Installation Instructions

Table of contents

Page 35.....	Included Components
Page 36.....	Hardware List and Getting Started
Page 37.....	ShockWave installation
Page 38.....	ShockWave Installation and Notes and Care
Page 39.....	Care of your Shockwaves
Page 40.....	Shock Adjustment





Major ComponentsIn the box

Item #	Part #	Description	QTY
1	982-10-805	5.2" Stroke HQ Series Shock	2
2	24090799	7000 Series 4" Diameter Air Spring	2
3	815-05-022	Shock Eyelet	2
4	90001994	5/8" ID Bearing (installed in shock and eyelet)	4
5	90001995	Bearing Snap Ring (installed in shock and eyelet)	8
6	90002043	1/2" ID Upper Bearing Spacers	8
7	90002327	Upper Mount	2
8	90002224	Driver Lower Mount	1
8	90002223	Passenger Lower Mount (not shown)	1
	234-00-153	Air Spring Locking Ring (not shown)	2
	99055000	Air Spring Locking Ring Set Screw (not shown)	2

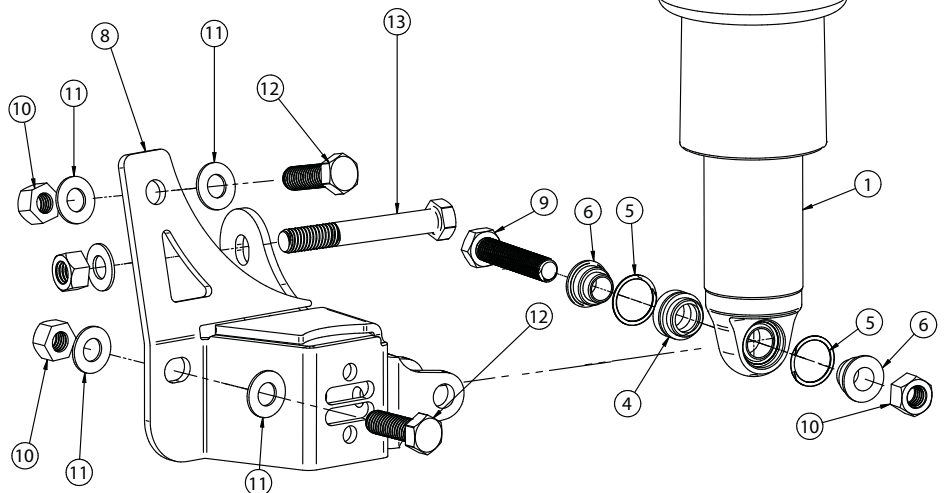
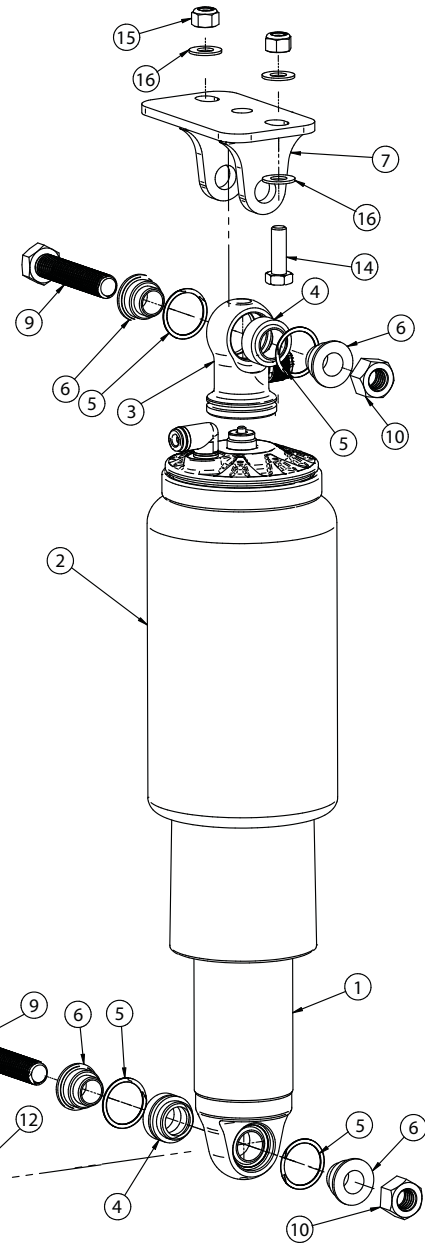

WARNING: ATTEMPTING TO REMOVE THE AIR FITTING WILL DAMAGE IT AND VOID THE WARRANTY.



Hardware ListIn the box

Item #	QTY	Part Number	Description	Location
9	4	99501050	1/2" -13 x 2 1/2" Hex Bolt	ShockWave to Mounts
10	10	99502009	1/2" -13 Nylok Nut	ShockWave to Mounts, Lower Bar Bolt
11	14	99503014	1/2" SAE Flat Washer	ShockWave to Mounts, Lower Bar Bolt
12	4	99501053	1/2" -13 x 1 1/2" Hex Bolt	Lower Mounts to Differential
13	2	99501065	1/2" -13 x 3 3/4" Hex Bolt	Lower Bar Bolt
14	4	99311011	5/16" -18 x 1 1/4" Hex Bolt	Upper Mounts to Frame
15	4	99312002	5/16" -18 Nylok Nut	Upper Mounts to Frame
16	8	99313001	5/16" SAE Flat Washer	Upper Mounts to Frame

Getting Started.....

Congratulations on your purchase of the Ridetech Rear Shockwave System. This system has been designed to give your car excellent handling along with a lifetime of enjoyment. One of the key features of this system is the adjustability. With the ShockWave system you have an adjustable shock along with the height adjustment of the air spring.

Disassembly

1. Raise and safely support the vehicle by the frame rails.
2. Using a jack, slightly raise the axle approximately 1". Remove the shock absorbers.
3. Lower the axle down enough to remove the coil springs.
4. The exhaust tail pipes may need to be removed and/or modified for ShockWave installation.

NOTE: Keep in mind the spring has pressure on it until you let the rear differential down to remove the springs.



ShockWave Installation

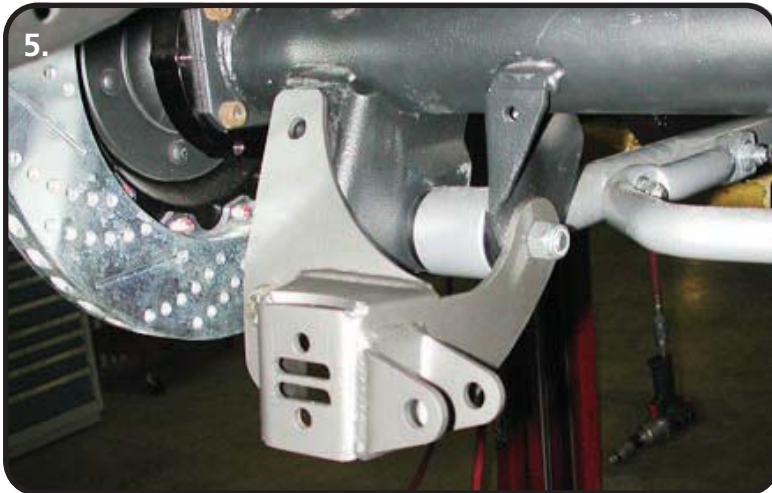

5. Remove the lower trailing arm mounting bolt. (Do one side at a time to keep the axle from rotating). Install the longer $\frac{1}{2}$ " x $3\frac{3}{4}$ " bolt through the lower trailing arm from the outside in. Install the lower bracket over the bolt and secure with a $\frac{1}{2}$ " Nylok nut and flat washer. Snug the Hardware, but do NOT fully tighten at this time.



6. The lower bolt hole in the back of the bracket will align with the factory shock stud hole. Use a $\frac{1}{2}$ " x $1\frac{1}{2}$ " bolt, Nylok nut and flat washers. The upper hole must be drilled with a $\frac{1}{2}$ " bit. The edge of the bracket should be parallel to the axle bracket. Use an centering punch and $\frac{1}{8}$ " bit to drill a pilot hole. A $\frac{1}{2}$ " x $1\frac{1}{2}$ " bolt, Nylok nut and flat washers will be used here as well. Torque all hardware to 75 ftlbs.

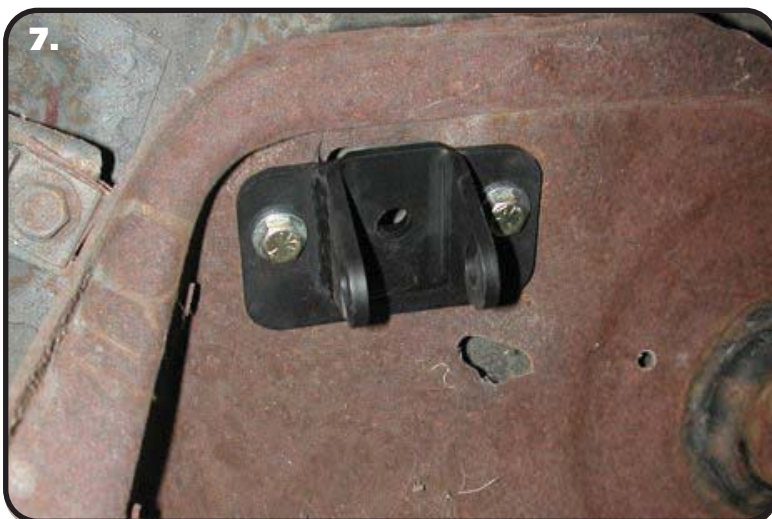

7. Fasten the new upper shock bracket into the factory shock location using the $\frac{5}{16}$ " x 1" bolts, flat washers and Nylok nuts supplied. Torque to 17 ftlbs.

Note: Position the bracket to offset the shock toward the center of the car.



ShockWave Installation



8. Fasten the ShockWave to the upper bracket using a 1/2" x 2 1/2" bolt and Nylok nut. 1/2" I.D. aluminum spacers must be installed on each side of the bearing. Torque to 75 ftlbs.

Note: The air fitting location can be rotated by twisting the bellow separate of the shock.



9. Fasten the ShockWave to the lower bracket using a 1/2" x 2 1/2" bolt and Nylok nut. 1/2" I.D. aluminum spacers must be installed on each side of the bearing. Torque to 75 ftlbs.

10. Double check air spring clearances throughout full suspension travel.

11. Ride height on this ShockWave is 14.5" from center eye to center eye. This should occur around 70-80psi, but may vary to vehicle weight and driver preference



Notes and Care of your Shockwaves

NOTES:

WARNING: ATTEMPTING TO REMOVE THE AIR FITTING WILL DAMAGE IT AND VOID THE WARRANTY.

TIGHTENING THE TOP 9/16"-18 NUT: SNUG THE NUT DOWN AGAINST THE TOP CAP. YOU NEED TO BE ABLE TO ARTICULATE THE SHOCK BY HAND.

You can clock the airfitting location on the ShockWave by turning the AirSpring assembly of the shock. Make sure the fitting doesn't contact the frame.

When cutting the airline, use a razor blade. The cut needs to be a clean cut and square for the airline to seal properly.

The Locking ring on the shock is NOT adjustable. These rings are set at the factory to optimize the AirSpring stroke with the shock stroke.

The care and feeding of your new ShockWaves

1. Although the ShockWave has an internal bumpstop, **DO NOT DRIVE THE VEHICLE DEFLATED RESTING ON THIS BUMPSTOP. DAMAGE WILL RESULT.** The internal bumpstop will be damaged, the shock bushings will be damaged, and the vehicle shock mounting points may be damaged to the point of failure. This is a non warrantable situation.
2. Do not drive the vehicle overinflated or "topped out". Over a period of time the shock valving will be damaged, possibly to the point of failure. This is a non warrantable situation! If you need to raise your vehicle higher than the ShockWave allows, you will need a longer unit.
3. The ShockWave is designed to give a great ride quality and to raise and lower the vehicle. **IT IS NOT MADE TO HOP OR JUMP!** If you want to hop or jump, hydraulics are a better choice. This abuse will result in bent piston rods, broken shock mounts, and destroyed bushings. This is a non warrantable situation.
4. Do not let the ShockWave bellows rub on anything. Failure will result. This is a non warrantable situation.
5. The ShockWave product has been field tested on numerous vehicles as well as subjected to many different stress tests to ensure that there are no leakage or durability problems. Failures have been nearly nonexistent unless abused as described above. If the Shockwave units are installed properly and are not abused, they will last many, many years. ShockWave units that are returned with broken mounts, bent piston rods, destroyed bumpstops or bushings, or abrasions on the bellows will not be warrantied.



Shock Adjustment

Shock Adjustment 101- Single Adjustable

Rebound Adjustment:

How to adjust your new shocks.

The rebound adjustment knob is located on the top of the shock absorber protruding from the eyelet.

You must first begin at the ZERO setting, then set the shock to a soft setting of 20.



-Begin with the shocks adjusted to the ZERO rebound position (full stiff). Do this by rotating the rebound adjuster knob clockwise until it stops.



-Now turn the rebound adjuster knob counter clock wise 20 clicks. This sets the shock at 20. (settings 21-24 are typically too soft for street use).

Take the vehicle for a test drive.



-if you are satisfied with the ride quality, do not do anything, you are set!

-if the ride quality is too soft increase the damping effect by rotating the rebound knob clock wise 3 clicks.

Take the vehicle for another test drive.



-if the vehicle is too soft increase the damping effect by rotating the rebound knob clock wise 3 additional clicks.



-If the vehicle is too stiff rotate the rebound adjustment knob counter clock wise 2 clicks and you are set!

Take the vehicle for another test drive and repeat the above steps until the ride quality is satisfactory.

Note:

One end of the vehicle will likely reach the desired setting before the other end. If this happens stop adjusting the satisfied end and keep adjusting the unsatisfied end until the overall ride quality is satisfactory.



Part # 11239122 - 1964-1967 GM A-Body Rear SwayBar

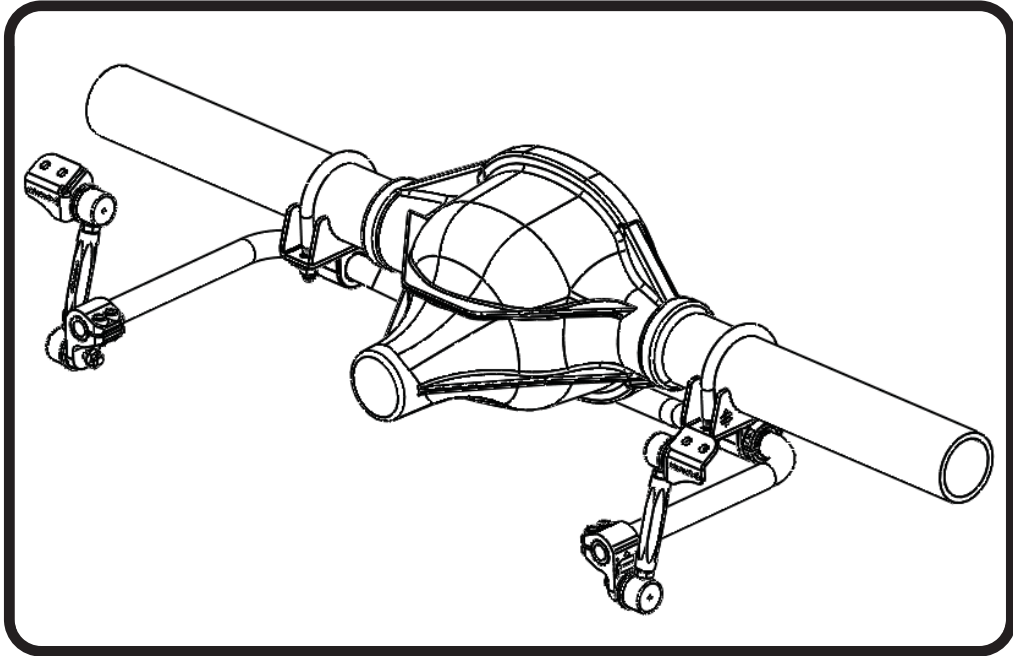

Recommended Tools



1964-1967 GM A-Body Rear SwayBar Installation Instructions

Table of contents	
Page 42.....	Included Components and Hardware List
Page 43-44....	SwayBar Installation

Hardware Torque Specifications

3/8"-16.....	30 ftlbs
7/16"-20.....	55 ftlbs
M10-1.5.....	37 ftlbs

Major ComponentsIn the box

Part #	Description	QTY
90001229	Rear SwayBar	1
90001249	Axle Bracket, 3" Axle Tube	2
70012496	Delrin Sway Bar Bushing Liner	2
90001250	Bushing Strap	2
90002539	SwayBar Bushing	2
90001269	Frame Tab, Driver	1
90001270	Frame Tab, Passenger	1
70014301	Clamp Ring	2
70014207	Clamp On SwayBar End	2
90002571	10mm 90 Degree End Links	4
90001253	SwayBar End Link Spacer, 4"	2
90000088	7/16" U-bolt	2

HARDWARE KIT99010084

QTY	Part Number	Description
TAB TO FRAME		
4	99371005	3/8"-16 x 1 1/4" Hex Bolt
4	99373002	3/8" Flat Washer
4	99372001	3/8"-16 Nylok Nut

QTY	Part Number	Description
SWAYBAR TO AXLE		
4	99433002	7/16" SAE Flat Washer
4	99432002	7/16"-20 Nylok Nut
SWAYBAR END CLAMP		
4	99371054	3/8"-16 x 7/8" Socket Head Bolt
1	90002276	Antisieze

Getting Started.....

This SwayBar Kit utilizes a Delrin Liner in the SwayBar Bushing. The Delrin Liner allows the SwayBar to move freely and quietly in the Bushing. The Delrin is self-lubricating, no lubrication is required.

THIS SWAYBAR ATTACHES TO THE AXLE AND FRAME.

1. Jack the vehicle up to a safe working height and support with jack stands. Make sure the jack stands are stable before working under the car.
2. Remove the stock sway bar if the car is equipped with one.



3. Open the Delrin Liner at the split and slip it over the SwayBar. Position it in the center of the straight area that it will ride in. Do this on both ends of the swaybar.



4. Open the SwayBar Bushing at the split and slip it **OVER** the Delrin Liner. Do this on both Delrin Liners.

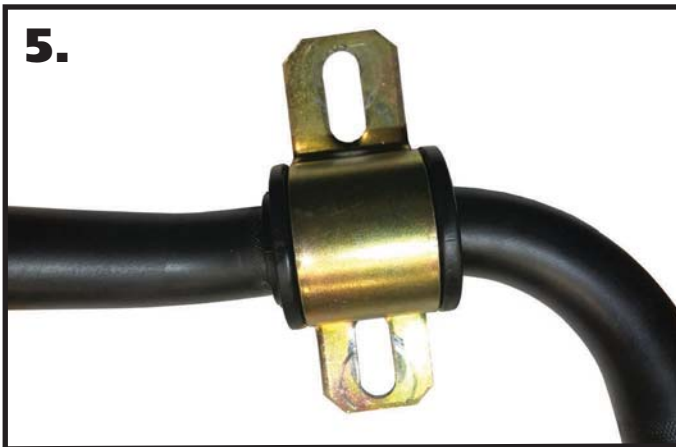

5.

5. Install the Bushing Straps over the SwayBar Bushings.



6.

6. Install the U-bolts onto the axle tube with the threads pointing down. You may need to raise the brake lines in the area of the u-bolts. The u-bolts will be approximately 23 1/2" apart and equal distance on each side from the brake backing plates.



7.

7. Install an Axle bracket onto each u-bolt with the flat side to toward the ground. The "teeth" of the mount should touch the axle tube.

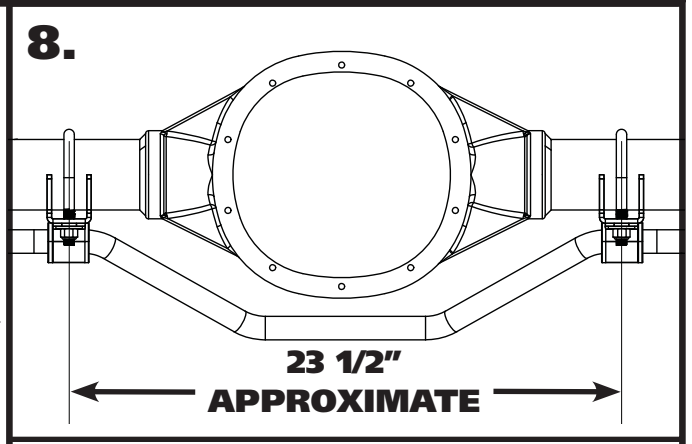

8.

8. **Diagram 8** illustrates the correct installation of the sway bar. Again, the axle brackets will be approximately 23 1/2" from center to center. The mounts should be spaced equal amounts from the brake backing plates, centering the sway bar on the axle.



9.

9. Hold the SwayBar in position on the car with the center bend toward the ground. Install a 7/16" Flat Washer & 7/16"-20 Nylok Nut on the threads of the u-bolts. Snug the hardware down and verify that it is centered and the axle mounts are level. Torque the u-bolt hardware.



10.

10. Apply Antisieze to (4) 3/8"-16 x 7/8" Socket Head Cap Screws and thread them into the Clamp-On Ends. Install a clamp-on end on each end of the bar. The End Link mounting hole should be mounted to the outside of the bar and pointing down. Start with the mount flush with the end of the bar.

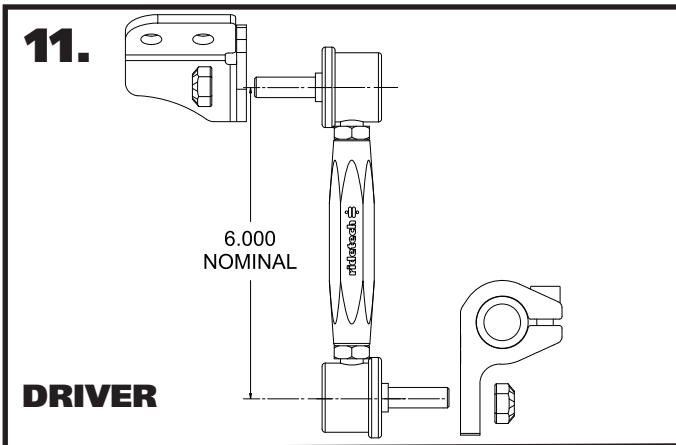

11. Set the Linkage to 6" center to center with the threaded studs pointed opposite directions. Snug the jam nuts against the center adapter. Attach the SwayBar Linkage to the Clamp-On Mount using the hardware on the linkage. Attach the correct tab to the top of the linkage with the gusset to the front. Use **Diagram 11** as a reference. Attach the linkages and tab to both sides.



12. Swing the tab up to the frame, keeping the linkage straight from side to side. Use the tab to mark the location of the holes that will need to be drilled. Drill the holes with a 3/8" drill bit. Install a 3/8" flat washer on each of (2) 3/8"-16 x 1 1/4" hex bolts and install them through the bracket and drilled holes. Install a 3/8" flat washer & 3/8"-16 nylok nut on each bolts sticking through the frame. Torque the hardware and repeat on the other side.



13. Install the locking rings on the outside of each bushing assembly. Use a hex key to take the locking ring apart. Reassemble it on the bar positioned next to the outside of the bushing assembly. Push the locking ring up against the bushing assembly and tighten.

14. We recommend getting the swaybar as level as possible at ride height and with no preload. Both of these steps are done by adjusting the end links. These end links can be adjusted from 6" to 6 3/4". Disconnect the end links from the swaybar and adjust one side to get the swaybar level. Reattach the end link to the swaybar and adjust the 2nd end link so that it goes in and out of the clamp-on mount with ease. This will be zero preload.

The rate of this sway bar is also adjustable. This is possible by changing the position of the clamp-on ends on the bar. The standard setting is with the clamp-on mounts even with the end of the bar, stiffest is with the clamp-on end positioned 3" from the end of the swaybar. The Diagram below shows the clamp-on mount in the softest and stiffest settings. The position of the mounts will be determined by several factors; spring rate, front bar size, and even tire size. We recommend running this rear sway bar with Ridetech's front sway bar (11239120) for the best performance.

MINIMUM RATE 200 LB/INCH

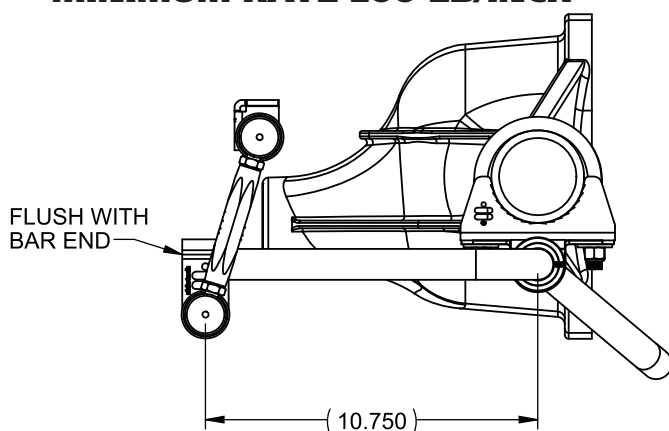

HIGH RATE 400 LB/INCH

