



350 S. St. Charles St. Jasper, In. 47546  
Ph. 812.482.2932 Fax 812.634.6632

[www.ridetech.com](http://www.ridetech.com)

**Part # 11150298**  
**65-70 Pontiac Fullsize**  
**Air Suspension Package System**

**Front Components:**

- |   |          |   |
|---|----------|---|
| 1 | 11151099 | Front CoolRide Kit for Stock Lower Arms |
| 1 | 11150501 | HQ Series Front Shock Kit               |

**Rear Components:**

- |   |          |  |
|---|----------|--|
| 1 | 11154099 | Rear CoolRide Kit for Stock Lower Arms |
| 1 | 11150701 | HQ Series Rear Shocks                  |



350 S. St. Charles St. Jasper, In. 47546  
Ph. 812.482.2932 Fax 812.634.6632

[www.ridetech.com](http://www.ridetech.com)

**Part # 11151099**  
**65-70 Pontiac Fullsize Front CoolRide Kit**

**Components:**

- 2 90006781 Air spring – 6.5” diameter, double convoluted, ¼” port
- 1 90000295 Front upper bracket (5” tall) - Driver’s side
- 1 90000296 Front upper bracket (5” tall) - Pass side
- 2 90000297 Front lower airspring bracket (short angled)
- 2 90001083 Medium bump stop

**Hardware:**

- |   |          |                       |                             |
|---|----------|-----------------------|-----------------------------|
| 2 | 99371001 | 3/8” x ¾” USS bolt    | Air spring to lower bracket |
| 4 | 99372002 | 3/8” USS Nylok nut    | Air spring to upper bracket |
| 6 | 99373003 | 3/8” SAE flat washer  | Air spring mounts           |
| 2 | 99373005 | 3/8” lock washer      | Air spring to lower bracket |
| 2 | 99435002 | 7/16” x 8” stud       | Upper bracket to frame      |
| 2 | 99433002 | 7/16” SAE flat washer | Upper bracket to frame      |
| 2 | 99432001 | 7/16” USS Nylok nut   | Upper bracket to frame      |

**DRIVER**

**PASSENGER**

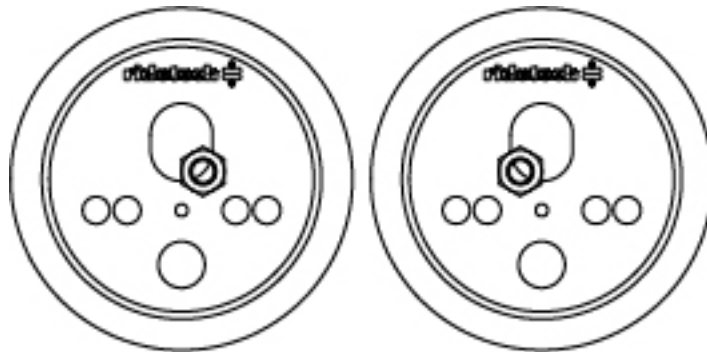

**NOTE:** THIS KIT HAS A DRIVER AND PASSENGER UPPER CUP BRACKET. A TOP VIEW IS SHOWN ABOVE.

# COOL RiDE®

## Installation Instructions

**\*\*\* Must Use RideTech Front Shock Kit \*\*\***



1. Apply thread sealant to the air fitting and screw it into the top of the air spring.
2. Place the upper cup bracket on top of the air spring and secure w/ two 3/8" Nylok nut and flat washers.
3. Fasten the lower bracke to the bottom of the air spring using a 3/8" x 3/4" bolt, lock washer and flat washer.
4. Screw the 8" all-thread stud into the nut at the bottom of the cup.

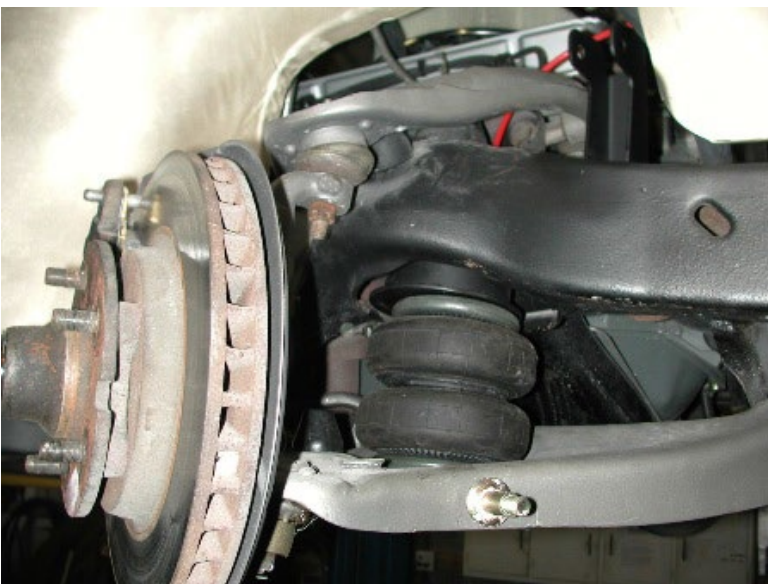

5. Place the assembly into the coil spring pocket with the stud sticking through the factory shock hole. Install 7/16" flat washer and Nylok nut onto stud.
6. The lower air spring bracket will simple rest in the coil spring pocket in the lower arm. The bracket may need to be rotated to achieve proper air spring alignment. The tall side of the bracket should be clocked toward the spindle.
7. Check air spring clearance throughout full suspension travel. **Allowing the air spring to rub will result in failure and is not a warrantable situation.**
8. Ride height on this air spring is between 4.5" – 5.5" tall.



350 S. St. Charles St. Jasper, In. 47546  
Ph. 812.482.2932 Fax 812.634.6632

[www.ridetech.com](http://www.ridetech.com)

**Part # 11150501**  
**65-70 Pontiac Front HQ Series Shock Kit**  
For Use With CoolRide

**Shock:**

- |   |            |                                      |
|---|------------|--------------------------------------|
| 2 | 986-10-036 | 4.75" Stroke Eye Top Shock Cartridge |
| 4 | 70011138   | 3/4" ID Shock Bushing                |
| 4 | 90002102   | 1/2" ID Inner Sleeve                 |

**Components:**

- |   |          |                       |
|---|----------|-----------------------|
| 2 | 90000011 | Upper shock bracket   |
| 2 | 90001619 | Shock Bolt Kit        |
| 2 | 90000471 | Cantilever pin spacer |

**Hardware:**

- |   |          |                        |                        |
|---|----------|------------------------|------------------------|
| 2 | 99501003 | 1/2" x 2 1/2" USS bolt | Shock to upper bracket |
| 2 | 99502001 | 1/2" USS Nylok nut     | Shock to upper bracket |

**Shock Dimensions:**

- |             |         |
|-------------|---------|
| Compressed: | 10 1/8" |
| Extended:   | 14 7/8" |

# COOL RiDE®

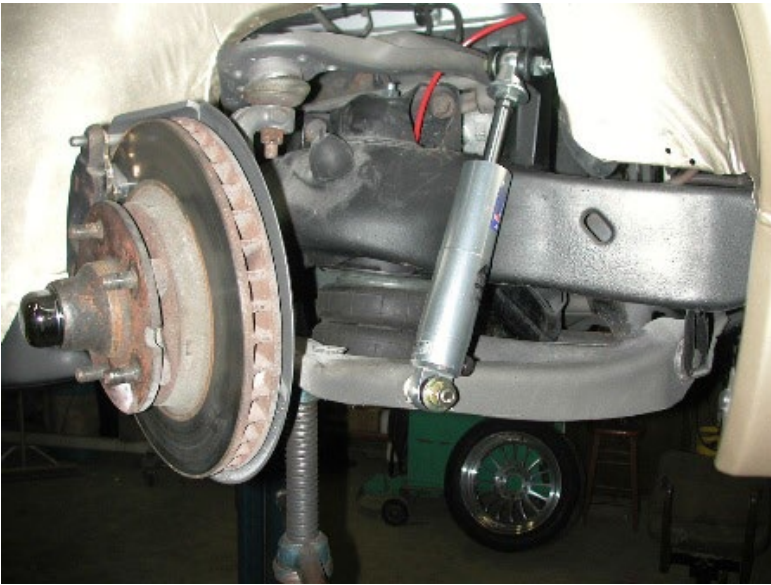

1. The upper shock mount must be welded to the frame. It may need to be cut down to match the stroke of the air spring and suspension. Make sure that when the suspension is fully compressed the shock is about  $\frac{1}{4}$ " from being fully compressed. Just tack weld the mount for now and install the lower shock stud and shock. The upper mount will use a  $2\frac{1}{2}$ " x  $\frac{1}{2}$ " bolt and Nylok nut. **Check to make sure the shock does not bottom out when the suspension is fully compressed.** If the shock bottoms out it could damage the shock or shock mounts.

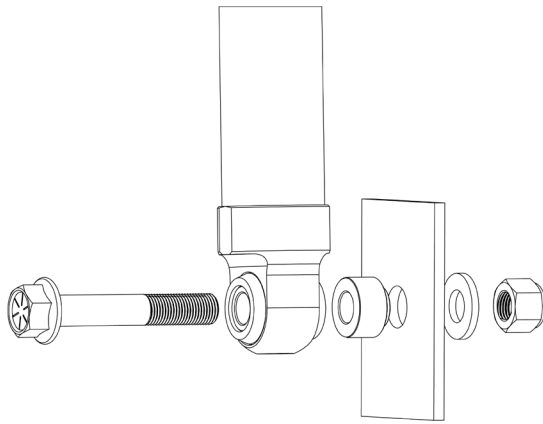

2. The shock must be relocated to the front side of the control arm. A  $.625$ " hole must be drilled in the lower control arm for the Cantilever pin to attach. This hole will be drill directly in front of the factory shock mount but may need to be moved in or out slightly to allow for maximum tire clearance and turning radius.



350 S. St. Charles St. Jasper, In. 47546  
Ph. 812.482.2932 Fax 812.634.6632

[www.ridetech.com](http://www.ridetech.com)

**Part # 11154099**  
**65-70 Pontiac Fullsize Rear CoolRide Kit**

**Components:**

|   |          |   |
|---|----------|---|
| 2 | 90009000 | Tapered sleeve air spring                       |
| 2 | 90000056 | Upper cup bracket                               |
| 2 | 90000224 | Upper washer (4" O.D. x .5" I.D.)               |
| 2 | 90000291 | Lower washer (2.563" O.D. x .438")              |
| 2 | 90000290 | Air spring roll plate (5.5" O.D. x 2.812" I.D.) |

**Hardware:**

|   |          |                       |                       |
|---|----------|-----------------------|-----------------------|
| 2 | 99435004 | 7/16" x 4 1/2" stud   | Cup bracket to frame  |
| 2 | 99432002 | 7/16" USS Nylok nut   | Cup bracket to frame  |
| 2 | 99433002 | 7/16" SAE flat washer | Cup bracket to frame  |
| 6 | 99371001 | 3/8" x 3/4" USS bolt  | Air spring to bracket |
| 6 | 99373003 | 3/8" SAE flat washer  | Air spring to bracket |
| 6 | 99373005 | 3/8" lock washer      | Air spring to bracket |



# COOLRiDE®

## Installation Instructions

1. Raise and support vehicle at a safe and comfortable working height.
2. Support the axle then remove the coil spring and shock. Refer to service manual for proper disassembly procedure. To help keep the axle in place, do one side at a time.

\*\*\* Must Use RideTech Rear Shock Kit \*\*\*



3. Apply thread sealant to a 90 deg. air fitting and screw it into the top of the air spring.

4. Place the upper air spring bracket on top of the air spring and secure with two 3/8" x 3/4" bolts, flat washers, and lock washers.

5. Thread the 2" stud into the nut in the bottom of the bracket.



6. Hold the air spring assembly up to the coil spring pocket with the stud protruding through the hole in the center of the coil spring pocket. Place the 4" diameter washer over the stud and tighten with a 7/16" Nyloc nut and flat washer.

**Note:** Some cars have a small hole in the frame and will not need the 4" washer.



7. Place the air spring plate over the lower coil spring mount on the axle. Extend the air spring so the bottom of it seats on top of the plate. Some cars will require trimming of the coil spring retainer to allow this.

8. Use the 3/8" x 1 1/4" bolt and 2.5" washer to secure the air spring to the axle.

9. Install the new shocks using the hardware supplied.

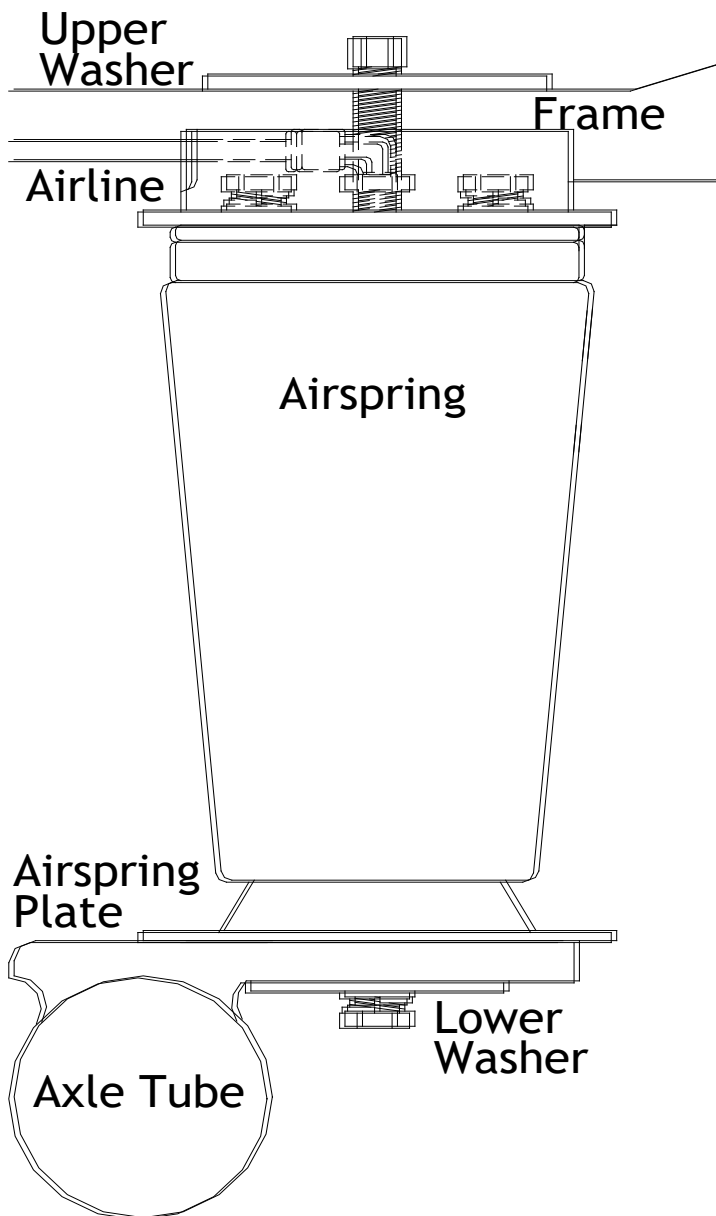

10. Check air spring clearance with exhaust and anything else that could rub against it. **Abrasion will cause air spring failure and is not a warrantable situation.**

11. Driving height on this air spring is 8 1/2"-9" tall. Maximum extended height is 12", minimum compressed height is 4 1/2". Allowing this air spring to exceed these dimensions will cause failure. The shock absorber and factory bump stop should keep the air spring within these limits.





350 S. St. Charles St. Jasper, In. 47546  
Ph. 812.482.2932 Fax 812.634.6632

[www.ridetech.com](http://www.ridetech.com)

**Part # 11150701**  
**65-70 Pontiac Fullsize HQ Series Rear Shock Kit**

**Shock:**

|   |            |                                      |
|---|------------|--------------------------------------|
| 2 | 986-10-020 | 7.55" Stroke Eye Top Shock Cartridge |
| 2 | 70011139   | 5/8" ID Shock Bushing                |
| 2 | 70011138   | 3/4" ID Shock Bushing                |
| 2 | 90002102   | 1/2" ID Shock Sleeve                 |
| 2 | 90002068   | Wide Trunion                         |

**Components:**

|   |          |                       |
|---|----------|-----------------------|
| 2 | 90000471 | Aluminum shock spacer |
| 2 | 90001619 | Shock bolt kit        |

**Hardware:**

|   |          |                       |                |
|---|----------|-----------------------|----------------|
| 4 | 99311001 | 5/16" x 1" USS bolt   | Shock to frame |
| 8 | 99313002 | 5/16" SAE flat washer | Shock to frame |
| 4 | 99312003 | 5/16" USS Nylok nut   | Shock to frame |

# ridetech

## Installation Instructions



1. Attach the upper T-bar to the frame in the oem location using the supplied 5/16 x 1" USS bolts, washers and Nylok nuts.

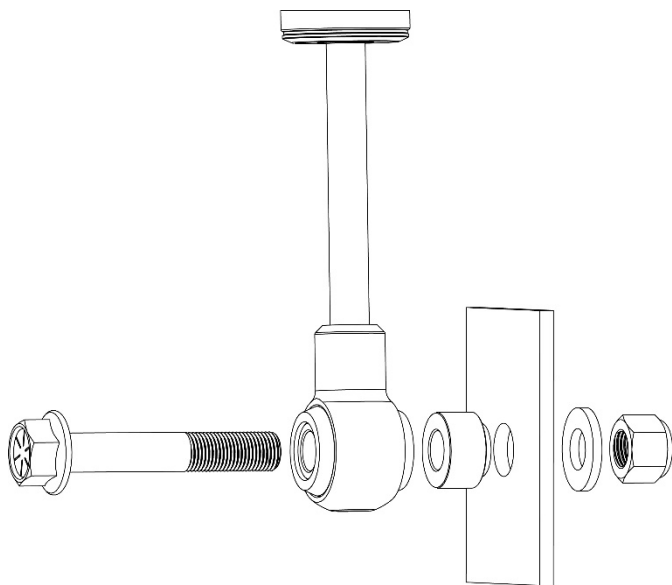

2. Attach the shock to the axle using the new shock bolt kit supplied.

# ridetech

350 S. St. Charles St. Jasper, In. 47546  
Ph. 812.482.2932 Fax 812.634.6632

[www.ridetech.com](http://www.ridetech.com)

## Shock adjustment 101- Single Adjustable

### Rebound Adjustment:

How to adjust your new shocks.

The rebound adjustment knob is located on the top of the shock absorber protruding from the eyelet or stud top. You must first begin at the ZERO setting, then set the shock to a street setting of 12.



-Begin with the shocks adjusted to the ZERO rebound position (full stiff). Do this by rotating the rebound adjuster knob clockwise until it stops.



-Now turn the rebound adjuster knob counter clock wise 12 clicks. This sets the shock at 12. (settings 21-24 are typically too soft for street use).

### Take the vehicle for a test drive.



-if you are satisfied with the ride quality, do not do anything, you are set!

-if the ride quality is too soft increase the damping effect by rotating the rebound knob clock wise 3 clicks.

### Take the vehicle for another test drive.



-if the vehicle is too soft increase the damping effect by rotating the rebound knob clock wise 3 additional clicks.



-if the vehicle is too stiff rotate the rebound adjustment knob counter clock wise 2 clicks and you are set!

Take the vehicle for another test drive and repeat the above steps until the ride quality is satisfactory.

### Note:

One end of the vehicle will likely reach the desired setting before the other end. If this happens stop adjusting the satisfied end and keep adjusting the unsatisfied end until the overall ride quality is satisfactory.